

**Unclassified**

**NEA/RWM/CPD(2006)2**



Organisation de Coopération et de Développement Economiques  
Organisation for Economic Co-operation and Development

**12-Oct-2006**

**English - Or. English**

**NUCLEAR ENERGY AGENCY**

**NEA/RWM/CPD(2006)2**  
**Unclassified**

**Radioactive Waste Management Committee (RWMC)**

**Management Board of the Co-operative Programme for the Exchange of Scientific and Technical Information concerning Nuclear Installations Decommissioning Projects**

**COMPREHENSIVE REPORT OF THE TASK GROUP ON ACTIVITY MEASUREMENTS AT RELEASE LEVELS**

**JT03215685**

Document complet disponible sur OLIS dans son format d'origine  
Complete document available on OLIS in its original format

**English - Or. English**

**Authors**

<b>Belgium</b>	Isabelle MAJKOWSKI Robert WALTHERY	CEN•SCK BELGOPROCESS
<b>France</b>	Philippe COLSON Gérald IMBARD Christophe LE GOALLER	EDF CEA CEA
<b>Germany</b>	Luis VALENCIA	FZK
<b>Spain</b>	Teresa ORTIZ	ENRESA
<b>Sweden</b>	Per DRAKE Shankar MENON	VATTENFALL AB MENON CONSULTING AB
<b>United Kingdom</b>	Richard GUNN Brian SYME	BNFL INSTRUMENTS AEA TECHNOLOGY

## FOREWORD

The NEA Co-operative Programme for the Exchange of Scientific and Technical Information Concerning Nuclear Installation Decommissioning Projects (CPD) is a joint undertaking of a limited number of organizations, mainly from NEA member countries. The objective of the CPD is to acquire information from operational experience in decommissioning nuclear installations that is useful for future projects. The working method is through sharing of scientific and technical knowledge drawn from a number of current decommissioning projects. Initiated in 1985, the CPD is administratively organized based on its formal, signed Agreement that was renewed in 1990 and 1995. The fourth five year period commenced in 2000 with the Agreement then subject to major revision and was not formally agreed and signed until April 2004.

This report describes generic results obtained by the CPD on available adequate methods of measurement. Although part of the information exchanged within CPD is confidential in nature and is restricted to programme participants, experience of general interest gained under the programme is released for broader use. Such information is brought to the attention of all NEA members through regular reports to the Radioactive Waste Management Committee (RWMC) of the NEA, as well as through experience documents such as this report. The Working Party on Decommissioning and Dismantling (WPDD) within RWMC would like to thank CPD for sharing the experiences from its important work.



## TABLE OF CONTENTS

1. INTRODUCTION .....	9
2. RADIOLOGICAL CHARACTERISATION: OBJECTIVES AND METHODOLOGY .....	11
2.1 Regulatory Aspects .....	11
2.2 Existing standards on activity measurements .....	15
2.3 Characterisation Procedures and Objectives .....	16
2.4 Radiation sources .....	17
2.5 Main parameters affecting measurement .....	19
2.6 Methodology for Components Monitoring at Release Levels .....	20
2.6.1 Selection of Release Criteria .....	20
2.6.2 Preliminary Surveys .....	20
2.6.3 Assessment of Monitoring and Sample Analysis Requirements .....	21
2.6.4 Selection of Methods and Instruments .....	22
2.6.5 Determination of Background and Radiation Levels .....	22
2.6.6 Final Survey .....	22
2.6.7 Documentation .....	23
2.6.8 Quality Assurance .....	23
2.6.9 Cost of Compliance Surveys .....	24
3. EQUIPMENT USED FOR RELEASE MEASUREMENTS .....	27
3.1 General .....	27
3.2 Overview of Detectors .....	28
3.3 Gas-filled detectors .....	30
3.3.1 General Characteristics .....	30
3.3.2 Ionisation Chambers .....	30
3.3.3 Proportional Counters .....	30
3.3.4 Geiger-Mueller Counters .....	31
3.4 Scintillation detectors .....	32
3.4.1 General Characteristics .....	32
3.4.2 Organic Scintillators .....	32
3.4.3 Inorganic Scintillators .....	33
3.5 Semiconductor diode detectors .....	34
3.6 Statistical Aspects .....	35
3.6.1 Counting statistics and background .....	35
3.6.2 Minimum detectable activity .....	36
3.7 Laboratory equipment .....	37
3.7.1 Alpha activity measurements .....	38
3.7.2 Beta activity measurements .....	39
3.7.3 Gamma spectrometry .....	39

4. OVERVIEW OF MEASUREMENT METHODS AND APPLICATIONS .....	41
4.1 Volumetric Measurements .....	41
4.1.1 Gamma measurements .....	41
4.1.1.1 <i>High Resolution Gamma Spectroscopy (HRGS)</i> .....	42
4.1.1.2 <i>Low Resolution Gamma Spectroscopy (LRGS)</i> .....	43
4.1.1.3 <i>Gross Counting and dose rate</i> .....	44
4.1.2 Neutron measurements .....	45
4.2 Surface Measurement .....	46
4.2.1 Alpha measurements on surface .....	46
4.2.2 Beta measurements on surface .....	47
4.2.3 Alpha and Beta detection .....	49
4.2.4 Gamma measurements on surface .....	49
4.2.5 Alpha and Beta measurements on internal surfaces .....	49
4.2.5.1 <i>Associated Gamma Radiation Measurement</i> .....	49
4.2.5.2 <i>Direct Detection Measurement</i> .....	50
4.2.5.3 <i>Air Ionisation Measurement</i> .....	50
4.3 Indirect Measurements .....	50
4.3.1 Sampling Techniques .....	51
4.3.2 Smear Tests .....	51
4.4 Aspects of application of the measurements techniques .....	52
4.4.1 Direct measurements of alpha emitters .....	52
4.4.2 Direct measurements of beta emitters .....	53
4.4.3 Gamma measurements .....	53
4.4.4 Indirect measurements of alpha and/or beta emitters .....	54
4.4.5 In situ Gamma Spectrometry (ISOCS) .....	54
5. STATE OF THE ART IN DIFFERENT COUNTRIES .....	61
5.1 National Regulation and Practice .....	61
5.1.1 Sweden .....	61
5.1.2 Spain .....	62
5.1.3 Belgium .....	63
5.1.4 France .....	63
5.1.5 Italy .....	63
5.1.6 Germany .....	63
5.1.7 UK .....	67
5.2 Practical Experiences of Devices used as Release Measurement Methods .....	68
5.2.1 France.....	68
5.2.2 Spain .....	69
5.2.3 Belgium .....	70
5.2.4 Germany .....	71
5.2.5 Sweden .....	73
5.2.6 UK .....	74
5.2.7 USA .....	75
6. CASES STUDIES .....	79
6.1 Belgoprocess Experience in Belgium .....	79
6.1.1 Unconditional Release of Decontaminated Concrete at the Eurochemic Reprocessing Plant .....	81
6.1.2 Unconditional Release Measurements of Decontaminated Metal Components from the Eurochemic Reprocessing Plant .....	83

6.2	Research Reactor R1, Stockholm, Sweden .....	84
6.2.1	Introduction.....	84
6.2.2	Release Measurements.....	84
6.2.3	Costs.....	85
7.	CRITICAL DISCUSSION ON METHODS AND TECHNIQUES .....	87
7.1	Germany-HDR .....	87
7.2	Germany-KKW .....	88
7.3	Decommissioning of the CP-5 Research Reactor .....	89
7.4	Multi-Purpose Research Reactor (M2FR) Karlsruhe .....	91
7.5	Release Measurements at Energiewerke Nord GmbH, Germany .....	92
7.6	Japan.....	92
8.	PROBLEMS ENCOUNTERED OUTSIDE THE NUCLEAR FIELD .....	97
8.1	Form of the Material .....	97
8.2	Measurements Problem .....	97
8.3	Regulation of NORM.....	98
9.	CONCLUSIONS .....	105





## 1. INTRODUCTION

In response to the growing interest in the decommissioning of nuclear facilities, the OECD Nuclear Energy Agency set up the Co-operative Programme on Decommissioning in 1985. Its basic scope is to facilitate the exchange of scientific and technical information between major decommissioning projects. Participation in the Programme has expanded significantly over the years such that there are organizations from 13 countries and 31 projects participating, with active support from the European Commission (CEC), the International Atomic Energy Agency (IAEA) and the International Union of Producers and distributors of Electrical Energy (UNIPEDE). The Programme is executed under an agreement between the participating organizations and companies. The agreement was renewed in September 1995 for its third five years period.

Many of the early projects in the Programme were on experimental or prototype plants. During the last five years, however, a number of projects for the decommissioning of commercial facilities - power generation, fuel and reprocessing plants - have joined the Programme. The "industrialization" process will continue, based on experience and technical information primarily gained from these projects, together with others who will possibly join. The increase in the number of participating projects in the Programme has made it one of the major forums today for the collection and dissemination of decommissioning information. The Programme has also developed into being a channel for the collective expression of the views of nuclear facility decommissioners, with hands-on experience of problems to be solved in the field.

The participating decommissioning projects cover both reactors and fuel facilities. The reactor types include BWR, PWR, PHWR, Gas-cooled/Water-cooled D<sub>2</sub>O-moderated reactors, GCR, AGR, HTGR and VVER. The fuel facilities consist mostly of reprocessing plants with two fuel material plants and an isotope processing facility. The type of information exchanged covers not only the technical aspects of the projects but also the major influences of the organization, economic, regulatory and other circumstances prevailing in the country or at the specific site concerned. When major topics are identified requiring more detailed investigations, special Task Groups have been created.

One such Task Group was established in 1992 to examine the means for minimizing the radioactive wastes arising from decommissioning operations together with maximizing the recovery of valuable materials. This study of the Task Group on Recycling and Reuse has recently been completed with regard to metallic wastes [1-1] and is to be continued looking at non-metallic wastes.

It has been concluded that, after treatment, significant quantities of waste generated from decommissioning can be recycled and reused. Indeed, recycle and reuse options provide a cost effective solution to the management of waste arisings. The most significant impediment to the use of recycle and reuse is the absence of consistent release standards within the nuclear industry. Several international organizations, like the IAEA and the EC, have proposed standards with the object of agreeing to an internationally accepted set of release levels.

The current recommendations of international organizations are aimed solely at minimizing radiological risks. The philosophy behind these recommendations are based on the IAEA document,

Safety Series No 89 [1-2], which was issued jointly by the IAEA and the OECD Nuclear Energy Agency (NEA) in 1988. Safety Series No 89 suggests

- a maximum individual dose/practice of about 10  $\mu\text{Sv}/\text{year}$ ,
- a maximum collective dose/practice of 1 manSievert/year

to determine whether the material can be cleared from regulatory control or other option should be examined.

The strict application of these allowable dose levels, without any broader consideration of other non-radiological risks that could be avoided by recycling, has led to recommendations of extremely low permitted activity levels in material to be released from regulation.

For applying these recommendations effectively, adequate methods of measurement must be available to demonstrate or verify that the activity levels are lower than the proposed levels. Measurements would have to be made under practical industrial conditions, where various constraints could significantly influence the results. The costs of activity measurements at extremely low levels on large quantities of equipment with complex geometries could be prohibitively high.

The Co-operative Programme has therefore established a special Task Group to study these problems in an analytical and structured manner. This report describes the findings of the group.

### **References for Chapter 1**

- [1-1] OECD/NEA, Nuclear Decommissioning, *Recycling and Reuse of Scrap Metals* (1996)
- [1-2] IAEA, *Principles for the Exemption of Radiation Sources and Practices from Regulatory Control*, Safety Series n° 89, Vienna (1989)

## **2 RADIOLOGICAL CHARACTERISATION: OBJECTIVES AND METHODOLOGY**

### **2.1 Regulatory Aspects**

The international discussions on release of materials for reuse or recycling are taking place mainly at:

- The International Commission on Radiological Protection (ICRP), which has supplied the basic recommendations regarding principles for protection from ionizing radiation [2-1].
- The International Atomic Energy Agency (IAEA) which has translated these general principles first into dose criteria [2-2] and then into recommendations on nuclide specific release levels [2-3].
- The European Commission (EC), who have prepared their own recommendations for countries within the European Union [2-4].
- The OECD/NEA's Task Group on Recycling and Reuse which can be considered as representing the implementers of the recommendations and criteria that are being drawn up by the IAEA and EC.

In 1988, the IAEA and the Nuclear Energy Agency (NEA), in co-operation, issued Safety Series No. 89 [2-2] to recommend a policy for exemptions (and clearance) from the basic and safety system of notification, registration and licensing that form the basis of regulatory control. Safety Series No. 89 suggests

- a maximum individual dose/practice of about 10  $\mu$ Sv/year.
- a maximum collective dose/practice of 1 manSievert/year.

to determine whether the material can be cleared from regulatory control or other options should be examined. A methodology to apply these principles on the recycling or reuse of material from nuclear facilities was subsequently presented. The results of this document were part of the input in the IAEA process of establishing unconditional release levels for solid materials [2-3]. This last mentioned report IAEA TECDOC 855 was issued in January 1996 on an interim basis for a period of about three years. This document presents recommended nuclide specific clearance levels for solid materials, shown in Table 2.1.

The EC recommendations – Radiation Protection 89 [2-4] – have been prepared for the clearance of metals from the dismantling of nuclear installations. The proposals cover steel, aluminum, copper and alloys of these metals. While the IAEA TECDOC 855 treated only unconditional clearance, the EC approach provides two options for releasing material:

- direct release based only on surface contamination (see Table 2.2),
- melting at a commercial foundry followed by recycle and reuse. Mass specific and surface specific levels are provided (see Table 2.3).

Table 2.1 IAEA Derived unconditional clearance levels [2-3]

Ranges of activity Concentration (Bq/g)	RADIONUCLIDES*	Representative single values of activity concentration Bq/g
0.1	<sup>22</sup> Na <sup>134</sup> Cs <sup>234</sup> U  <sup>24</sup> Na <sup>137</sup> Cs <sup>235</sup> U <sup>54</sup> Mn <sup>152</sup> Eu <sup>238</sup> U <sup>60</sup> Co <sup>210</sup> Pb <sup>237</sup> Np <sup>65</sup> Zn <sup>226</sup> Ra <sup>239</sup> Pu <sup>94</sup> Nb <sup>228</sup> Ra <sup>240</sup> Pu <sup>110m</sup> Ag- <sup>228</sup> Th <sup>241</sup> Am <sup>124</sup> Sb <sup>230</sup> Th <sup>244</sup> Cm  <sup>232</sup> Th	0.3
<1.0		
≥1.0	<sup>58</sup> Co <sup>111</sup> In <sup>59</sup> Fe <sup>113</sup> I <sup>90</sup> Sr <sup>192</sup> Ir <sup>106</sup> Ru <sup>210</sup> Po	3
<10		
≥10	<sup>51</sup> Cr  <sup>7</sup> Co <sup>129</sup> I <sup>99m</sup> Tc <sup>144</sup> Ce <sup>123</sup> I <sup>201</sup> Tl <sup>251</sup> I <sup>241</sup> Pu	30
<100		
≥100	<sup>14</sup> C <sup>89</sup> Sr <sup>32</sup> P <sup>90</sup> Y <sup>36</sup> Cl <sup>99</sup> Tc <sup>55</sup> Fe <sup>109</sup> Cd	300
<1000		
≥1000	<sup>3</sup> H <sup>63</sup> Ni <sup>35</sup> S <sup>147</sup> Pm  <sup>45</sup> Ca	3 000
<10 000		

\*<sup>220</sup>Ra and <sup>222</sup>Ra were not considered in this classification.

Table 2.2 EC Nuclide specific clearance levels for direct reuse of metal items [2-4]

Nuclides	Surface specific (Bq/cm <sup>2</sup> )	Nuclides	Surface specific (Bq/cm <sup>2</sup> )
<sup>3</sup> H	10 000	<sup>171</sup> Tm	10 000
<sup>14</sup> C	1 000	<sup>182</sup> Ta	10
<sup>22</sup> Na	1	<sup>181</sup> W	100
<sup>35</sup> S	1000	<sup>185</sup> W	1 000
<sup>36</sup> Cl	100	<sup>185</sup> Os	10
<sup>40</sup> K	10	<sup>192</sup> Ir	10
<sup>45</sup> Ca	100	<sup>204</sup> Tl	100
<sup>46</sup> Sc	10	<sup>210</sup> Pb	1
<sup>53</sup> Mn	10 000	<sup>207</sup> Bi	1
<sup>54</sup> Mn	10	<sup>210</sup> Po	0.1
<sup>55</sup> Fe	1000	<sup>226</sup> Ra	0.1
<sup>56</sup> Co	1	<sup>228</sup> Ra	1
<sup>57</sup> Co	10	<sup>228</sup> Th	0.1
<sup>58</sup> Co	10	<sup>229</sup> Th	0.1
<sup>60</sup> Co	1	<sup>230</sup> Th	0.1
<sup>59</sup> Ni	10 000	<sup>232</sup> Th	0.1
<sup>63</sup> Ni	1 000	<sup>231</sup> Pa	0.1
<sup>65</sup> Zn	10	<sup>232</sup> U	0.1
<sup>73</sup> As	1 000	<sup>233</sup> U	1
<sup>75</sup> Se	10	<sup>234</sup> U	1
<sup>85</sup> Sr	10	<sup>235</sup> U	1
<sup>90</sup> Sr	10	<sup>236</sup> U	1
<sup>91</sup> Y	100	<sup>238</sup> U	1
<sup>93</sup> Zr	100	<sup>237</sup> Np	0.1
<sup>95</sup> Zr	10	<sup>236</sup> Pu	0.1
<sup>93m</sup> Nb	1 000	<sup>238</sup> Pu	0.1
<sup>94</sup> Nb	1	<sup>239</sup> Pu	0.1
<sup>93</sup> Mo	100	<sup>240</sup> Pu	0.1
<sup>97</sup> Tc	100	<sup>241</sup> Pu	10
<sup>97m</sup> Tc	1 000	<sup>242</sup> Pu	0.1
<sup>99</sup> Tc	1 000	<sup>244</sup> Pu	0.1
<sup>106</sup> Ru	10	<sup>241</sup> Am	0.1
<sup>108m</sup> Ag	1	<sup>242m</sup> Am	0.1
<sup>110m</sup> Ag	1	<sup>243</sup> Am	0.1
<sup>109</sup> Cd	100	<sup>242</sup> Cm	1
<sup>113</sup> Sn	10	<sup>243</sup> Cm	0.1
<sup>124</sup> Sb	10	<sup>244</sup> Cm	0.1
<sup>125</sup> Sb	10	<sup>245</sup> Cm	0.1
<sup>123m</sup> Te	100	<sup>246</sup> Cm	0.1
<sup>127m</sup> Te	100	<sup>247</sup> Cm	0.1
<sup>125</sup> I	100	<sup>248</sup> Cm	0.1
<sup>129</sup> I	10	<sup>249</sup> Bk	100
<sup>134</sup> Cs	1	<sup>248</sup> Cf	1
<sup>135</sup> Cs	100	<sup>249</sup> Cf	0.1

<sup>137</sup> Cs	10	<sup>250</sup> Cf	0.1
<sup>139</sup> Ce	10	<sup>251</sup> Cf	0.1
<sup>144</sup> Ce	10	<sup>252</sup> Cf	0.1
<sup>147</sup> Pm	1 000	<sup>254</sup> Cf	0.1
<sup>151</sup> Sm	1 000	<sup>254</sup> Es	1
<sup>152</sup> Eu	1		
<sup>154</sup> Eu	1		
<sup>155</sup> Eu	100		
<sup>153</sup> Gd	10		
<sup>160</sup> Tb	10	<sup>170</sup> Tm	1 000

Table 2.3 EC Nuclide specific clearance levels for metal scrap recycling [2-4]

	Mass specific (Bq/g)	Surface Specific (Bq/cm <sup>2</sup> )	Nuclide	Mass specific (Bq/g)	Surface specific (Bq/cm <sup>2</sup> )
<sup>3</sup> H	1 000	100 000	<sup>171</sup> Tm	1 000	10 000
<sup>14</sup> C	100	1 000	<sup>182</sup> Ta	1	10
<sup>22</sup> Na	1*	10	<sup>181</sup> W	100	1 000
<sup>35</sup> S	1 000	1 000	<sup>185</sup> W	1 000	1 000
<sup>36</sup> Cl	10	100	<sup>185</sup> Os	1	10
<sup>40</sup> K	1	100	<sup>192</sup> Ir	1	10
<sup>45</sup> Ca	1 000	100	<sup>204</sup> Tl	1 000	1 000
<sup>46</sup> Sc	1*	10	<sup>210</sup> Pb	1*	1
<sup>53</sup> Mn	10 000	100 000	<sup>207</sup> Bi	1	10
<sup>54</sup> Mn	1	10	<sup>210</sup> Po	1	0.1
<sup>55</sup> Fe	10 000	10 000	<sup>226</sup> Ra	1	0.1
<sup>56</sup> Co	1	10	<sup>228</sup> Ra	1	1
<sup>57</sup> Co	10	100	<sup>228</sup> Th	1	0.1
<sup>58</sup> Co	1	10	<sup>229</sup> Th	1*	0.1
<sup>60</sup> Co	1	10	<sup>230</sup> Th	1*	0.1
<sup>59</sup> Ni	10 000	10 000	<sup>232</sup> Th	1*	0.1
<sup>63</sup> Ni	10 000	10 000	<sup>231</sup> Pa	1*	0.1
<sup>65</sup> Zn	1	100	<sup>232</sup> U	1	0.1
<sup>73</sup> As	100	1 000	<sup>233</sup> U	1	1
<sup>75</sup> Se	1	100	<sup>234</sup> U	1	1
<sup>85</sup> Sr	1	100	<sup>235</sup> U	1	1
<sup>90</sup> Sr	10	10	<sup>236</sup> U	10	1
<sup>91</sup> Y	10	100	<sup>238</sup> U	1	1
<sup>93</sup> Zr	10	100	<sup>237</sup> Np	1	0.1
<sup>95</sup> Zr	1	10	<sup>236</sup> Pu	1	0.1
<sup>93m</sup> Nb	1 000	10 000	<sup>238</sup> Pu	1*	0.1
<sup>94</sup> Nb	1	10	<sup>239</sup> Pu	1*	0.1
<sup>93</sup> Mo	100	1 000	<sup>240</sup> Pu	1*	0.1
<sup>97</sup> Tc	1 000	1 000	<sup>241</sup> Pu	10	10
<sup>97m</sup> Tc	1 000	1 000	<sup>242</sup> Pu	1*	0.1
<sup>99</sup> Tc	100	1 000	<sup>244</sup> Pu	1*	0.1
<sup>106</sup> Ru	1	10	<sup>241</sup> Am	1*	0.1

<sup>108m</sup> Ag	1	10	<sup>242m</sup> Am	1	0.1
<sup>110m</sup> Ag	1	10	<sup>243</sup> Am	1*	0.1
<sup>109</sup> Cd	10	100	<sup>242</sup> Cm	10	1
<sup>113</sup> Sn	1	100	<sup>243</sup> Cm	1	0.1
<sup>124</sup> Sb	1	10	<sup>244</sup> Cm	1	0.1
<sup>125</sup> Sb	10	100	<sup>245</sup> Cm	1*	0.1
<sup>123m</sup> Te	10	100	<sup>246</sup> Cm	1*	0.1
<sup>127m</sup> Te	100	100	<sup>247</sup> Cm	1	0.1
<sup>125</sup> I	1	100	<sup>248</sup> Cm	1*	0.1
<sup>129</sup> I	1	10	<sup>249</sup> Bk	100	100
<sup>134</sup> Cs	1*	10	<sup>248</sup> Cf	10	1
<sup>135</sup> Cs	10	1 000	<sup>249</sup> Cf	1	0.1
<sup>137</sup> Cs	1	100	<sup>250</sup> Cf	1	0.1
<sup>139</sup> Ce	10	100	<sup>251</sup> Cf	1	0.1
<sup>144</sup> Ce	10	10	<sup>252</sup> Cf	1	0.1
<sup>147</sup> Pm	10 000	1 000	<sup>254</sup> Cf	1	0.1
<sup>151</sup> Sm	10 000	1 000	<sup>254</sup> Es	10	1
<sup>152</sup> Eu	1	10			
<sup>154</sup> Eu	1	10			
<sup>155</sup> Eu	10	1 000			
<sup>153</sup> Gd	10	100			
<sup>160</sup> Tb	1	10			
<sup>170</sup> Tm	100	1 000			

\*Raised to 1 Bq/g

Currently a lot is happening in the regulatory field, both internationally and nationally in many countries. For example:

- Both Safety Series 89 and TECDOC 855 are being revised. The NEA Task Group on Recycling and Reuse are campaigning strongly for exposure to workers and the public from both the nuclear and non-nuclear industries to be regulated under the same radiation protection criteria.
- The US Nuclear Regulatory Commission has published the rules for site release: Subpart E, 10CRF20.1402, on an individual dose criterion of 250  $\mu$ Sv/year. This year, it has issued the DRAFT NUREG 1640: Radiological Assessments for Clearance of Equipment and Materials from Nuclear Facilities. This is based on an individual dose criterion of 10  $\mu$ Sv/year.

As seen above, the present discussions use a large number of terms such as clearance, exemption, free release, release for unrestricted reuse, release for regulatory control, unconditional recycling... Whatever the terms used, this report concerns itself with the measurements necessary to achieve the release from regulatory control for subsequent use in a radiological unrestricted fashion.

## 2.2 Existing Standards on Activity Measurements

International standards and reference publications in the field of radioactivity measurements concentrate more on measurements procedures, than on release levels:

- measurement methods (e.g. ISO 7503-1 to 7503-3 on estimating surface contamination);

- measuring instruments (e.g. IEC 325:1981 on alpha, beta and alpha-beta contamination meters and contamination monitors - IEC 846:1989 on beta, X and gamma radiation dose equivalent and dose equivalent rate meters for use in radiation protection);
- measurement uncertainty (e.g. ISO/DIS 11929-1 to -8 on determining the decision threshold and detection limit for ionizing radiation measurement).

Low-level radioactivity measurements are covered by a separate standard (ISO/DIS 11932 describing specifications concerning “Activity Measurements for solid materials considered as nonradioactive wastes and intended to be recycled, reused or scrapped”); it refers to the above-mentioned standards and discusses the following points in particular:

- direct and indirect surface contamination measurements;
- specific activity measurements;
- sampling methodology.

National standards can also be applied :

- Germany: DIN 25 482 "Nachweisgrenze und Erkennungsgrenze bei Kernstrahlungsmessungen", on which the national regulations for measurement of radioactive material are based.  
DIN 25 457 “Aktivitätsmeßverfahren für die Freigabe von radioaktiven Reststoffen und kerntechnischen Anlagenteilen“, on which the national regulations for release measurements of radioactivematerials are based.  
DIN 44 801 “Oberflächen-Kontaminationsmeßgeräte und –monitoren für Alpha-, Beta- und GammaStrahlung”, on which the national regulations for measurement of radioactive material are based.
- France : NF M 60-302 “Mesures non destructives par spectrométrie gamma.”
- Sweden: Sweden : SSI FS 1996:2 “Statens stralskyddsinstitutets foreskrifter om utforsel av gods och olja fran zonindelad område vid karntekinska anlaggningar”, national release levels for free use of material, for deposition as waste for municipal waste handling, or for burning of oil from nuclear facilities.

### 2.3 - Characterisation Procedures and Objectives

Theoretical and/or experimental radiological characterisation methods are extensively and regularly used in controlling every aspect of the nuclear industry. The decommissioning of nuclear facilities is no exception, and characterisation methods are employed from the final shutdown to complete rehabilitation of the premises or site.

The characterisation procedure as applied to decommissioning covers three broad categories of operations, differing by their importance and their objectives.

The **initial radiological inventory** is intended to assess as comprehensively, precisely and exhaustively as possible the quantity, type, form and distribution of the radioactivity contained in the facility after final shutdown. This is an essential step, and the results are crucial in establishing a decommissioning plan of action. It affects many aspects, including the following:

- safety (source term, design basis accident, evolution of radiological risks);
- radiological protection (occupational exposure, impact on the public and the environment);
- operating techniques (manual, telemanipulation, robotics);



- decontamination strategy;
- waste management (special processing, conditioning, transport, interim storage, disposal);
- time frame (operational chronology based on diminishing exposure dose rates);
- costs.

In addition to the above parameters, this report addresses the effects of the initial radiological characterisation on optimizing the methods, equipment and means required throughout the dismantling operations and during the final inspections (see below).

At this stage, a sufficiently detailed and precise characterisation can allow a preliminary discrimination – even before dismantling begins – between items with no added artificial radioactivity, very low level radioactive items and radioactive items. Section 3 of this report describes the “release level” measurement methods applicable, depending on the circumstances, from the initial radiological inventory stage.

**Routine characterisation of decommissioning operations** covers several aspects:

- process monitoring (e.g. estimating the effectiveness of a decontamination method);
- health physics inspections corresponding to particular activities (e.g. breaching of containment barriers, radioactive emissions due to the use of certain cutting techniques, etc.);
- measurement of waste, equipment and materials resulting from dismantling.

The third point will be considered in detail in this report, as it concerns low-level measurements performed on items that can be subject to management routes other than those leading to storage or disposal as radioactive waste.

The **final inspection of the premises or site** is intended to measure the residual radioactivity after dismantling and removal of all radioactive waste, sources and equipment.

This inspection occurs at the end of decommissioning to stage 3 (with or without demolition of the civil engineering work), and ensures that the residual radioactivity levels are indeed systematically below the specified limits for reuse of the premises or unconditional release of the site.

It may be performed as applicable by sampling campaigns, or by measuring the total surface area.

## 2.4 Radiation Sources

The wide variety of activities performed in nuclear facilities results in the presence of an extremely broad range of radionuclides, including natural isotopes, fission products and activation products. The list is considerably shorter, however, with regard to decommissioning of these facilities or to management of the resulting decommissioning waste. Except for the initial radioactive inventory, when it is performed at the moment of the final shutdown, these operations are generally deferred for a few months or years after shutdown, during which the short-lived radionuclides disappear by simple radioactive decay.

**Table 2.4** lists the main radionuclides found in decommissioned nuclear facilities, with half times greater than a few months, together with their half-lives and principal decay modes. The range of half-time extremely broad: although elements with radioactive half-lives of less than a few months are

rarely encountered, some artificial radionuclides have half-lives exceeding a million years. In this table, natural radionuclides are highlighted by the brackets (nat).

Concerning the decay modes, if neutron emissions (not mentioned in table) following spontaneous fission of some radionuclides are taken into account, all the types of emitted particles are encountered. A large variety of characterisation methods and measurement equipment is therefore necessary to deal with the radiological configuration of each decommissioning operation.

Table 2.4 Principal Radionuclides Encountered during Decommissioning of Nuclear Facilities

Isotope	Half-life (years)	Emission	Isotope	Half-life (years)	Emission
<sup>3</sup> H	1.2 E+01	β <sup>-</sup>	<sup>134</sup> Cs	2.1 E+00	β <sup>-</sup> , γ
<sup>14</sup> C	5.7 E+03	β <sup>-</sup>	<sup>135</sup> Cs	2.3 E+06	β <sup>-</sup>
<sup>32</sup> Si	6.5 E+02	β <sup>-</sup>	<sup>137</sup> Cs	3.0 E+01	β <sup>-</sup> , γ
<sup>36</sup> Cl	3.0 E+05	β <sup>-</sup>	<sup>133</sup> Ba	1.1 E+01	EC, X, γ
<sup>39</sup> Ar	2.7 E+02	β <sup>-</sup>	<sup>137</sup> La	6.0 E+04	EC, X
<sup>40</sup> K (nat)	1.3 E+09	β <sup>-</sup>	<sup>144</sup> Ce	8.0 E-01	β <sup>-</sup> , γ
<sup>41</sup> Ca	1.0 E+05	EC	<sup>147</sup> Pm	2.6 E+00	β <sup>-</sup>
<sup>54</sup> Mn	8.6 E-01	EC, γ	<sup>151</sup> Sm	9.0 E+01	β <sup>-</sup>
<sup>55</sup> Fe	2.7 E+00	EC, X	<sup>152</sup> Eu	1.3 E+01	EC, β <sup>-</sup> , X, γ
<sup>60</sup> Co	5.3 E+00	β <sup>-</sup> , γ	<sup>154</sup> Eu	8.6 E+00	β <sup>-</sup> , X, γ
<sup>59</sup> Ni	7.5 E+04	EC, X	<sup>155</sup> Eu	5.0 E+00	β <sup>-</sup> , X, γ
<sup>63</sup> Ni	9.6 E+01	β <sup>-</sup>	<sup>166m</sup> Ho	1.2 E+03	β <sup>-</sup> , X, γ
<sup>90</sup> Sr	2.8 E+01	β <sup>-</sup>	<sup>171</sup> Tm	1.9 E+00	β <sup>-</sup>
<sup>93</sup> Zr	1.5 E+06	β <sup>-</sup>	<sup>232</sup> Th (nat)	1.4 E+10	α
<sup>93m</sup> Nb	1.4 E+01	IT, X	<sup>205</sup> Pb	1.4 E+07	EC
<sup>94</sup> Nb	2.0 E+04	β <sup>-</sup> , γ	<sup>234</sup> U	2.5 E+05	α, X
<sup>93</sup> Mo	3.0 E+03	EC, X	<sup>235</sup> U (nat)	7.0 E+08	α, γ
<sup>99</sup> Tc	2.1 E+05	β <sup>-</sup>	<sup>238</sup> U (nat)	4.5 E+09	α
<sup>106</sup> Ru	1.0 E+00	β <sup>-</sup> , γ	<sup>237</sup> Np	2.1 E+06	α, X, γ
<sup>108m</sup> Ag	1.3 E+02	EC, γ	<sup>238</sup> Pu	8.8 E+01	α, X
<sup>110m</sup> Ag	7.0 E-01	β <sup>-</sup> , γ	<sup>239</sup> Pu	2.4 E+04	α
<sup>109</sup> Cd	1.3 E+00	EC, X	<sup>240</sup> Pu	6.6 E+03	α, X
<sup>113m</sup> Cd	1.4 E+01	β <sup>-</sup>	<sup>241</sup> Pu	1.4 E+01	β <sup>-</sup>
<sup>121m</sup> Sn	5.5 E+01	β <sup>-</sup> , X	<sup>241</sup> Am	4.3 E+02	α, X, γ
<sup>125</sup> Sb	2.8 E+00	β <sup>-</sup> , γ	<sup>242</sup> Cm	4.5 E-01	α, X
<sup>129</sup> I	1.6 E+07	β <sup>-</sup>	<sup>244</sup> Cm	1.8 E+01	α, X

Some radionuclides, daughters of the natural radionuclides  $^{232}\text{Th}$ ,  $^{238}\text{U}$  and  $^{235}\text{U}$  may also be sometimes considered. At enhanced concentrations, the daughters of these nuclides, among which the gaseous Radon isotopes, can cause significant internal or external exposures.

## 2.5 Main Parameters Affecting Measurements

Characterisation of dismantled items with very low radioactivity levels and intended for recycling or reuse can be an extremely complex and expensive operation if their radiological characteristics are unknown. In such circumstances, numerous additional measurement and analysis methods must be implemented to determine the activity of each radionuclide liable to be present in or on the material.

In order to optimize the means required for characterisation, it is essential to determine beforehand the most accurate possible data on the nature, composition, distribution and order of magnitude of the actual radioactivity. Information concerning the radiological properties alone is not sufficient to determine the best characterisation method; allowance must also be made for the nature, physical condition and shape of the components. Where possible, collection of the necessary data begins at the initial radiological inventory stage. The conditions of early characterisation are related mainly to questions of feasibility (accessibility), safety and particular operating conditions (e.g. protection against contamination), to the estimated radiological hazard (dosimetry) and to the cost of the operations.

It is important to make maximum use of the historical information on the facility, its operations and processes. The physical, chemical and radiological information should be combined with knowledge of the transport mechanisms available to disperse the radionuclides during and after the facility operation, in order to assess the nature and distribution of the radionuclide inventory

The following is a list of the parameters significantly affecting the choice of a characterisation process, regardless of the time it is implemented:

- Type of facility (reactor or fuel cycle facility) and historical data.
- Radiological environment in the measurement zone:
  - natural and artificial radioactivity levels;
  - ambient particles and emission spectra.
- Physical condition of the materials to be inspected (solid, porous, powdery, fibrous).
- Material density.
- Geometry of the items:
  - dimensions;
  - massive or hollow components;
  - outer surfaces (flat or curved);
  - complex shapes (accessibility of all areas).
- Nature of the radioactivity and its fixation on the materials:
  - surface contamination (fixed or transferable);
  - contamination gradient in the thickness of the parts;
  - chemical form;
  - activation beneath the surface.
- Heterogeneity of the radioactivity distribution.
- Types of radiation ( $\alpha$ ,  $\beta$ , X or  $\gamma$ , neutrons).
- Emission spectra and fluctuations (energy and relative number of particles).
- Specific activity values to allow selective classification of items for authorized reuse outside the nuclear regulatory domain.

Considering the number of factors and their effects (the preceding list is not necessarily exhaustive), it is clear that optimizing the radiological characterisation methodology is a complex undertaking.

## **2.6 Methodology for Component Monitoring at Release Levels**

Although full optimization of the characterisation methods, strictly speaking, is an extremely difficult objective to attain, well established guidelines are available to aid in selecting the necessary means. The IAEA's *Technical Reports Series No. 293* [2-5] describes the steps for ensuring that recycled materials comply with the permissible limits for release:

- selection of the applicable release criteria;
- preliminary survey;
- determination of monitoring and sample analysis requirements;
- selection and calibration of instruments;
- determination of background radiation levels;
- final survey;
- documentation;
- quality assurance.

The extent to which each of these generic steps is applied will depend on many factors, which could be specific to a particular country, facility or component. Much more detailed planning will be necessary to release a building or site for reuse than to release a simple component such as a small pump. However, the above-mentioned steps should be completed for each case as part of the compliance survey.

The quality of the compliance survey will to a large extent depend on the quality of the people doing the job. It is important that well trained personnel be employed in compliance surveys.

The responsibility for development and implementation of the monitoring programme for large facilities can be attributed to a body, independent of the decommissioning contractor, but has to be approved by the competent authority.

In the following sections, the basic steps in the compliance survey plan are discussed in greater detail.

### **2.6.1 Selection of Release Criteria**

Criteria for the unrestricted release of materials are usually set by competent national authorities: unconditional clearance levels are calculated through the study of scenarios that could result in annual individual doses of  $10 \mu\text{Sv h}^{-1}$ . In the same time, work is in progress to develop international criteria (cf. § 2.1).

### **2.6.2 Preliminary Surveys**

Information is available from a variety of sources to assist in the development of the detailed survey plan, in the selection and procurement of suitable instruments and in the selection of required samples. For example, during the preliminary planning for the decommissioning of a nuclear facility, a detailed assessment is made of the inventory and distribution of the radionuclides likely to be present in various parts of the plant and sites. These data are obtained from a good knowledge of the plant and its process streams, from theoretical calculations of induced activity and from measurement sand/or samples taken during operational and maintenance tasks. This information is usually supplemented after the final shutdown of the plant by a preliminary monitoring survey of the facility

or component to confirm previous records, supply additional data and look for hot spots or non-uniform distribution of activity.

Before the actual monitoring of components for release can commence, the radionuclide spectrum must have been determined qualitatively and quantitatively. In addition, the likelihood of changes in the ratios between various radionuclides must be known (e.g. from natural decay, physical or chemical transports mechanism). These data can be determined from environmental sampling, radiological surveying and by a knowledge of the radioactive process streams in that part of the facility from which the component comes.

This preliminary information will also be of value in deciding which plant components are likely to be suitable candidates for recycling or reuse. For example, if preliminary core samples or calculations show that the concentration of activation products in steel is above the acceptable level, the material would no longer be considered for recycling for unrestricted use.

For simple components being considered for release, the preliminary and final surveys might be made at the same time.

### **2.6.3 Assessment of Monitoring and Sample Analysis Requirements**

Having agreed with the competent authority on the release criteria for identified components of the plant which may be suitable for release, it is necessary to draw up the procedures for an efficient and comprehensive compliance survey for each component. The detailed plan will depend on the type of component and its operating history as well as the release criteria. However, it will generally include one or more of the following measurement techniques:

- (i) Dose rate measurements.
- (ii) Direct surface contamination measurements using alpha and/or beta/gamma sensitive probes.
- (iii) Indirect measurement of loose contamination by swabbing and counting under a shielded detector.
- (iv) Bulk measurements of large volumes of material by *in situ* gamma spectrometry or borehole logging.
- (v) Sampling of materials and liquors to confirm the assumed radionuclide content and subsurface distribution.

The sampling programme and the accompanying monitoring requirements for facilities having fixed ratios of radionuclides are relatively straightforward. For example, in a natural UO<sub>2</sub> plant, monitoring for gamma activity without sample analysis is adequate for compliance purposes since the ratios of alpha/beta/gamma activity are usually known. Similarly, ingots made from radioactive scrap metal can be released on the basis of a small number of samples because of the homogeneous nature of the ingot.

On the other hand, isotopic compositions and their effect on survey instruments must be checked more frequently by laboratory analysis or spectrometric survey instruments for components arising from a reprocessing plant since the ratio of alpha and beta to gamma activity will change from one area of the plant to another.

#### **2.6.4 Selection of Methods and Instruments**

The type of instrument used for the compliance survey will be determined by the characteristics of the contamination and by the scale of the component. These factors will also influence the sampling techniques and sample preparation methods used for laboratory analyses. Suitable instruments can be selected by consulting manufacturers' catalogues to compare the characteristics of the types of instruments available, talking with technical representatives and discussing the problem with other experts in this field of work.

#### **2.6.5 Determination of Background and Radiation Levels**

Since release criteria are often stated in terms of radioactivity levels above background, the determination of background data is a vital step in any compliance program. The wide variety of materials, equipment, buildings and sites which could become candidates for unrestricted release makes it difficult to use the same approach for all background measurements.

For sites, the natural background radiation levels are often used in the monitoring programme if these levels were recorded before the plant was built. Otherwise, measurements of the background levels of nearby areas which have not been contaminated by plant operations could be used.

For the final release of materials and equipment, areas' having low background radiation levels either on the site or nearby can be used to simplify the monitoring, especially if release levels are low. If possible, items to be released can be placed inside a shielded monitoring cell for measurement which provides reduced background radiation levels

#### **2.6.6 Final Survey**

For the final survey of a facility (or of one of its component parts) to ensure compliance with release criteria, it is assumed that the item has been decontaminated to acceptable levels of residual activity. It is also assumed that all materials and equipment known to have activity above acceptable levels have been removed. The extent of the termination surveys in actual plants will vary considerably depending on the type of plant and on other factors. General procedures for the final survey are briefly described below; detailed procedures can be found in Ref. [2-6].

A facility being surveyed for unrestricted release is usually divided into discrete subdivisions to make implementation of the survey and recording of data much easier. These subdivisions can be made on the basis of factors such as operating history, character and quantity of known contamination within a part of the facility, topography or variance of gamma dose rate within the subdivision. A building can be further subdivided into separate survey units such as room, story or a large piece of equipment. The floors, walls and roofs of buildings are usually divided into square grids of about one or two meters on a side to facilitate monitoring. Each block is monitored for the various forms of radioactivity which could possibly be there, and swab samples are taken. If activity levels are fairly consistent, all blocks may not be measured for all radionuclides. The number of measurements would probably be greater for grid blocks known to have been exposed to higher contamination levels.

Sites are divided into similar areas for surveying, but grid dimensions are usually larger than for buildings.

For components in which it is likely that the contamination could have penetrated into the material, for example soil or concrete, core samples or borehole monitoring would be required to confirm compliance both at depth and on the surface.

In some case, the distribution of measurement and sample points must have a statistically sound basis such that the results demonstrate compliance with an adequate level of confidence. Sampling points, whether they are for *in situ* measurements, swabs or samples, can be selected on any of a number of different statistical basis, including:

- random sampling;
- stratified random sampling (i.e. random within a stratum or survey unit);
- systematic sampling (based on the grid system).

The selection of the statistical base hinges on the need to achieve a high (e.g. 95%) confidence level in the overall component contamination level for the minimum number of sampling points. Assessment for the site decommissioning problem [2-6] has demonstrated that the stratified random sampling approach is the most economical where instrument readings and sample analyses across the site vary by a factor of three or more. Thus the random set of samples (minimum of 30 per stratum) from each stratum or survey unit is regarded as a separate population or group which is independently compared with the release criteria.

The collected data must be ordered in a way that relates the readings to positional coordinates that ensure unique identification. This coordinate system would normally be of an XYZ nature for buildings, and XY for sites.

#### **2.6.7 Documentation**

The importance of proper documentation for every aspect of the compliance survey cannot be overemphasized. A basic requirement is that the location of the monitoring or sampling point and its relevant data be unambiguously identified and related to a master plan or drawing. Without definitive documentation, the regulatory inspector cannot be sure that compliance with criteria has been achieved, and cannot perform suitable spot-check monitoring to confirm the results.

A standard form should be used to record the primary measurements or sample results to ensure that all appropriate data are recorded.

Secondary documentation to collate the large number of primary reports will consist of master plans with survey readings added as well as tables and computer files. These data must be presented in a form that accurately depicts the radiological condition of the component and can be readily understood by the regulatory inspector.

For large facilities or sites, professional assessment of statistical results is essential to establish definitive compliance with release criteria.

#### **2.6.8 Quality Assurance**

The purpose of a quality assurance (QA) on monitoring for compliance with release criteria is to ensure that sampling, analysis, monitoring, documentation, interpretation and use of data generated for this purpose will not result in the release of a component that could constitute a public health hazard. The importance of having a well thought-out QA cannot be overemphasized.

The QA must start with the detailed action plan and be an essential part of every step until the component has been released for recycling or reuse.

The reader is referred to documents such as Ref. [2-6] for further information.

### **2.6.9 Cost of Compliance Surveys**

The cost of ensuring that a component being released for unrestricted use complies with release criteria can be highly variable, and depends on many factors such as the type and size of the component, the radionuclides present, release criteria, labor costs and analytical costs [2-7].

Materials used in the survey could include sampling tools and containers, plastic bags, photographic film and protective clothing. The instrumentation can range from a single portable survey monitor for a simple component to a large number and variety of instruments for a large component such as a reactor building. For surveying remote sites, a mobile laboratory could be useful. Soil sampling costs are to a large extent determined by the labor costs to take the samples and by the analytical costs, which depend on the type of analyses and level and type of radioactivity to be assayed. Automated sample analysis equipment may be used to reduce analytical costs if large numbers of samples are to be assayed.

After the survey has been completed and samples have been analyzed, funds must also be allocated for evaluating the results and documenting them in a report. The cost of this work and the type and size of the report will vary according to the size and complexity of the component.

The estimated cost of such a survey must be included in the cost-benefit and other analyses made to determine if the particular component is worth considering for recycling or reuse.

In the following sections, the instrumentation and techniques used for radiological characterisation are reviewed.

## **References for Chapter 2**

- [2-1] *1990 Recommendations of the International Commission on Radiological Protection*. ICRP 60, Pergamon Press (1991)
- [2-2] INTERNATIONAL ATOMIC ENERGY AGENCY *Principles for the Exemption of Radiation Sources and Practices from Regulatory Control*, IAEA Safety Series No. 89, Vienna 1988
- [2-3] INTERNATIONAL ATOMIC ENERGY AGENCY *Clearance Levels for Radionuclides in Solid Materials, Interim Report for Comment*, IAEA – TECDOC 855, January 1996
- [2-4] EUROPEAN COMMISSION, Radiation Protection 89, *Recommended radiological protection criteria for the recycling of metals from the dismantling of nuclear installations*. Luxembourg 1988
- [2-5] IAEA, *Factors Relevant to the Recycling or Reuse of Components Arising from the Decommissioning and Refurbishment of Nuclear Facilities*, Technical Report Series n° 293, Vienna (1988)
- [2-6] HOLOWAY, C.F., et al., *Monitoring for Compliance with Decommissioning Termination Survey Criteria*, Rep. NUREG/CR-2082, prepared by the ORNL for the USDOE (1981)



- [2-7] WITHERSPOON, J.P., *Technology and Cost of Termination Survey Associated with Decommissioning of Nuclear Facilities*, Rep. ORNL/CR-2241, prepared by the ORNL for the USDOE (1982)



### 3. EQUIPMENT USED FOR RELEASE MEASUREMENTS

#### 3.1 General

The detection of radiation is based on its interactions and the energy deposited in the material of which detector is made. Therefore to use detectors and interpret the results of the measurement it is useful to know how radiation interacts and what the consequences of the various interactions are.

The topics presented here should be considered only as an introduction to this subject. They are oriented to general aspects considered important for radiation measurements. In general, for the discussion ionizing radiation is divided into three groups: Charged particles; photons (gamma or X-rays) and neutrons.

- Charged particles: Alpha and beta particles lose energy mainly through interactions with atomic electrons in the absorbing medium. The energy transferred to the electron causes excitations and Ionisations. Another effect is that when charged particles are slowed down very rapidly they emit energy in the form of X-rays (Bremsstrahlung effect). This effect is more important in the case of beta radiation and high-density material. It has not practical implications on the choice of a detector.
- Photons: X and gamma radiations interact with matter through a variety of mechanisms, the three most important are the photoelectric effect, Compton scattering and pair production. In the two first cases the energy of the photon is totally or partially transferred to an atomic electron. These atomic electrons subsequently lose energy as described above. Finally pair-production occurs when an energetic photon ( $E > 1.02 \text{ MeV}$ ) may be converted in a positron-electron pair.

The relative importance of these three types of gamma-ray interaction varies with the gamma energy, and the density of the absorber: Basically, photoelectric effect is predominant at low energy, up to a few hundreds of keV, whereas Pair production is predominantly confined to high energies, above 5 MeV. Between a few hundreds of keV and a few MeV, Compton Effect or multi scattering effect followed by photoelectric absorption tend to predominate.

This indirect capability of Ionisation is used to detect X and gamma photons. The different kinds of effects can be used to measure photons or to perform spectrometric analysis.

- Neutrons: Neutrons are uncharged and cannot cause Ionisation directly. As gamma radiations, neutrons ultimately transfer their energy to charged particles. In addition neutrons may be captured by a nucleus usually resulting in gamma-emission. These processes are very complicated. Neutronic radiation measurement is not usual in relation with release measurements; although neutrons can be used to detect very low level of transuranic elements within more dedicated equipments.

Another interesting point is the penetrating power of the different types of radiation:

- Alpha particles are massive and travel relatively slowly through matter. They rapidly lose their energy and only travel short distances through media.
- Beta particles are very much smaller than alpha particles and travel much faster. They lose their energy more slowly than alpha particle although this effect is very dependent on beta energy.
- Gamma radiations lose most of its energy by interaction with atomic electrons. They travel large distances in dense media. Thus they are not easily completely absorbed.
- Neutrons give up their energy through a variety of interactions, which are very dependent on the neutron energy. Neutrons are very penetrating and they will travel large distances in dense media.

### 3.2 Overview of detectors

Detection devices are based on the above described effects of radiation interactions. Most of the instruments available use detectors based on gas Ionisation. Some crystals or solids exhibit effects attributable to excitation, including scintillation, thermoluminescence and the photographic effect. In this chapter, the basic principles of those systems commonly used in practical release measurements are described.

Table 3.1 Instrument overview for release measurements

Measurement Technique	Applicability		
	Gas filled detectors	Scintillator based detectors	Semi-conductor based detectors
<b>Volumetric measurements</b>			
High resolution gamma spectrometry			×
Low resolution gamma spectrometry		×	
Gross gamma counting	×	×	
Neutron measurements	×		
<b>Surface measurements</b>			
$\alpha$ (or/and) $\beta$ detection	×	×	
$\gamma$ measurement	×	×	×
<b>Indirect Measurements</b>			
Sampling techniques	×	×	×
Smear Tests	×	×	×
<b>Mass spectrometry</b>	N.A.	N.A.	N.A.

Table 3.2 Overview of instruments characteristics

Type			Radiation	Energy Resolution	Efficiency
Gas filled		Ionisation	Alpha Beta Gamma	*Moderate *Moderate Poor	High High Poor
		Proportional	Alpha Beta Gamma	*Moderate *Moderate Poor	High High Moderate
		G-M	Gamma	Poor	Moderate
Scintillators	Inorganic	ZnS	Alpha	Moderate	High
		CsI(Tl)	Beta	Moderate	High
		NaI(Tl), CsI(Tl)	Gamma	Moderate	High
	Organic	Anthracene	Alpha	Poor	Moderate
		Anthracene, stilbene, plastics	Beta	Poor	Moderate
Plastics		Gamma	Poor	Poor	
Semi-conductor		Silicium semi- conductors	Alpha	High	High
		Germanium semi- conductors	Gamma	High	Moderate

*\* Alpha and Beta measurement with gas filled detectors is useful only when the source can be positioned inside the detector or when the source is in close proximity to the detector and a very thin window is used.*

#### Comparison between different detectors

With the various types of detectors, we obtain, for a particle of 3 MeV:

- |   |                         |
|---|-------------------------|
| 1 - semi-conductor: 3 eV/ionisation:              | 1 000 000 ionisations   |
| 2 - gas detectors: 30 eV/ionisation:              | 100 000 ionisations     |
| 3 - scintillator; 3 eV/photon at < 1% efficiency: | 10 000 photons detected |

In terms of resolution; i.e. precision of the spectrum, the 3 types of detectors can be classified according to the order given above.

Semi-conductors are clearly superior and are virtually the only detectors capable of being used for  $\gamma$  spectrometry analysis where the mixtures of radio-elements to be analyzed become more complex.

### **3.3 Gas-filled detectors**

#### **3.3.1 General Characteristics**

Gas filled detectors are the oldest but still very useful radiation detectors. The absorption of radiation in the gas results in the production of ion pairs. A voltage applied between two electrodes causes the negative ions to be attracted to the positive electrode, and positive ions to the negative electrode. The flow of ions to the respective electrodes produces an electric current, which is measured.

Three types of gas filled detectors can be found: Ionisation chamber, proportional counters, Geiger Muller counters. The main difference between these devices is related with the high voltage, which produces different current outputs.

#### **3.3.2 Ionisation Chambers**

The typical form of an Ionisation chamber consists of a cylindrical, conducting chamber, with a central electrode. The gas contained in the chamber is often dry air at atmospheric pressure. The voltage applied between the electrodes is moderate. The current produced by ions is extremely low, and a sensitive circuit is required to measure it precisely.

Ionisation chambers are used to some extent for detection of all types of particles producing either primary or secondary Ionisation. They are simple and rugged devices, which can provide a reliable determination of the gamma absorbed dose at low level. With a Mica window ( $7 \text{ mg/cm}^2$ ), Beta dose rate measurement is possible. Ionisation chambers are common in laboratories to perform alpha spectrometry measurements.

#### **3.3.3 Proportional Counters**

In a proportional counter, the voltage applied between the central wire and the wall is higher than in Ionisation chamber.

Gas flow proportional counters are sensitive to both alpha and beta radiations, and less sensitive to gamma, due to the low stopping power of the fill gas. The detector consists of a cell with a thin Mylar window. Within the detector gas is purged, generally a mixture of argon (90%) and methane (10%) - known as P10.

Proportional counters are almost always operated in pulse mode. Due to the phenomenon of gas multiplication, that amplifies the charge created by the Ionisation of the gas. Pulses are therefore larger than those of the ion chambers, and require less amplification in the associated electronic equipment. The pulse caused by alpha particle will be significantly larger than that caused by beta or gamma radiation, thus allowing alpha - beta discrimination. A bias voltage can be chosen so only alpha or only beta events are detected.

This kind of device is used to measure alpha or beta surface contamination. The detector is held close to the surface being monitored for good counting efficiency -particularly important for alpha measurements, and the surface is slowly scanned to indicate contamination levels.

Gas Flow proportional counters does not allow the determination of radiation energy or identification of specific radionuclides. The  $2\pi$  efficiency for alpha ranges between 30 and 40%. For beta, it ranges between 10 and 70 %, depending on beta energy. The efficiency for gamma is below 1%.

The active probe area usually ranges between 100 cm<sup>2</sup> and 600 cm<sup>2</sup>. Larger surfaces can be obtained when an array of gas proportional counters is arranged. In such cases, the counters are interfaced through counting electronics to a multi-channel scalar card.

The thin Mylar window is not robust, so easily damaged rendering the detector unusable. This is why contact measurements are not advisable. Incomplete flushing with gas can cause non uniform responses over the area of detectors

Since they have proved to be rapid, reliable, cheap and sensitive, proportional counters are widely used for release measurements. They also can be used for the detection and spectroscopy of soft X-rays, or low energy gamma rays, and are widely used for neutron detection.

### 3.3.4 Geiger-Mueller Counters

If the voltage within the gas counter is increased still further, the gas amplification is so great than a single ionizing particle produces an avalanche of Ionisation, resulting in a very large pulse.

The figure below is a schematic representation of the device. It consists of a cylindrical tube with a thin wire running along its axis. The tube will typically contain air or Argon, at low pressure. A high voltage is applied between the tube and the wire creating a strong electric field in the vicinity of the wire. The voltage can be adjusted so it is slightly lower than what is required to instigate a discharge between the wire and the wall of the tube. Alpha, beta or gamma radiation entering through the window causes Ionisation of the gas contained within the tube. The ions produced trigger an electric discharge, which is subsequently counted by simple pulse processing electronics.

The size of the pulse is the same, regardless of the quantity of energy initially deposited, and is governed more by the external circuit than the counter itself. Because they are cheap and robust, GM counters are widely used for counting beta particles, gamma or X-rays and can monitor material down to free release levels.

Alpha particles can also be detected, but thin windows are required, or the source must be placed inside the tube.

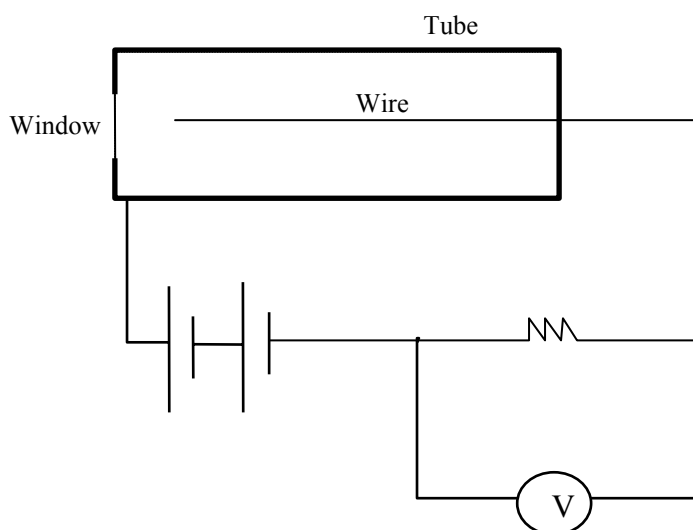

### 3.4 Scintillation detectors

#### 3.4.1 General Characteristics

Many types of scintillation counters have been devised and used for radiation measurement. They are capable of great sensitivity and high count rates, and can measure absorbed dose, exposure or flux if calibrated for the energy range of interest.

Scintillators are materials (solids or liquids) that produce scintillations of light when ionizing radiation passes through them. The amount of light produced in the scintillator is very small. It must be amplified before it can be recorded as a pulse or in any other way. The amplification or multiplication of the signal is achieved with a device called a *photomultiplier tube*. It accepts a small amount of light, amplifies it many times and produces an electrical pulse that can be amplified and counted. The intensity of this pulse is proportional to the energy lost by incident individual particles (alpha or beta) or photons responsible for the pulse. In a spectrometer the amplified pulse heights can be analyzed by a single or multichannel analyzer to obtain the energy spectrum.

The operation of a scintillation detector may be divided into two broad steps: absorption of incident radiation energy by the scintillation material and production of light and the second one, amplification of this light by the photomultiplier and production of the output pulse.

Scintillation detectors have found wide application in the measurement of ionizing radiation. For most purposes, two types of scintillator are used: organic scintillators and inorganic crystals. Crystals are used when high-energy resolution and photon absorption is needed; they are relatively expensive and must be sealed against atmospheric moisture. The main characteristics of scintillation detectors are summarized in Table 3.2.2.

The main advantages of scintillation counting are: high efficiency since the ionizing medium has a relatively high density and large areas of phosphors can be used, high precision and counting rates since the light pulses have very short duration. For the detection of gamma rays, large volumes of plastic scintillators are necessary. They also can be used for surface contamination.

#### 3.4.2 Organic Scintillators

The materials that are efficient organic scintillators belong to the class of aromatic compounds. Combining several compounds forms them. The luminescence process in organic materials is a molecular process. One of the most important differences between organic and inorganic scintillators is the response time, which is less than 10 ns for the organic scintillators and the about 10  $\mu$ s for the inorganic scintillators. This makes them suitable for high activities measurements.

- Anthracene and Stilbene

Two of the most important organic scintillators are anthracene and trans-stilbene. They have a similar density. Anthracene has the highest light conversion efficiency of all organic scintillators, which is still only about one-third of the light conversion efficiency of NaI(Tl) and a decay time very short about 30 ns. Anthracene can be obtained in several shapes and sizes. It can be used for low energy emitters such as  $^{14}\text{C}$ . Anthracene crystals of about 20  $\text{cm}^2$  are available, as well as anthracene coated on Perspex detectors with sensitive areas up to 100  $\text{cm}^2$ .



Trans-stilbene has a shorter decay time between 4 and 8 ns. Its light conversion efficiency is about half of anthracene. It can be obtained as a clear, colourless, single crystal with a size up several millimeters. Stilbene crystals are sensitive to thermal and mechanical shock.

- liquid scintillators

The organic liquid scintillators consist of a mixture of a solvent with one or more solutes. Liquid scintillators are very useful for detectors with large volume when it is needed to increase efficiency, but the most important use of liquid scintillators is the measurement of very low energy beta emitters. In this case the sample is dissolved in the scintillator to obtain very high detection efficiency and  $4\pi$  geometry. This kind of measurement can only be performed into the laboratory.

- plastic scintillators

The plastic scintillators may be considered as a mixture of organic scintillators. They have properties similar to those of liquid organic scintillators, but their advantage is that they do not need a container. Plastic scintillators can be made into a lot of shapes and sizes as thin fibers or thin sheets. They are inert to water, air, and many chemicals.

Plastic scintillators are also mixtures of a solvent and one or more solutes. Polystyrene and polyvinyltoluene are the most frequently used solvents. Some commercial names of common plastic scintillators are: Pilotb, NE102, NE110.

### 3.4.3 Inorganic Scintillators

The inorganic scintillators are crystals of inorganic salts, primarily the alkali halides, containing small amounts of impurities as activators for the luminescent process. Examples are NaI(Tl), CsI(Tl), CaF<sub>2</sub>(Eu) and LiI(Eu). The element in parentheses is the impurity or activator.

The luminescence in inorganic scintillators can be explained in terms of the allowed and forbidden energy bands of a crystal. Thus a portion of the original energy of the charged particle which passes through the crystal is converted to light, into scintillation.

- NaI(Tl) The most commonly used scintillator for gamma rays is NaI(Tl). It has been produced in single crystals of up to 0.75 m in diameter and considerable thickness (0.25 m). Its relatively high density and high atomic number combined with the large volume make it a gamma ray detector with very high efficiency. Although semiconductor detectors have better energy resolution, they cannot replace the NaI(Tl) when large detector volumes are needed. Its light-conversion efficiency is the highest of all the inorganic scintillators. The detector has a short time constant which allows the instrument to measure a wide range of activities from natural background intensities upwards. As a material has many undesirable properties. It is brittle and sensitive to temperature gradients and thermal shocks. It is also so hygroscopic that it should be kept encapsulated at all the times.
- The size of the crystal is also important, too large crystal increases the background, whereas too small crystal reduces counting efficiency and decreases spectrometric characteristics.
- CsI(Tl) has a higher density than NaI. Therefore, its efficiency for gamma rays is higher, in spite of a lower light conversion efficiency (45% of NaI(Tl) at room temperature). It is slightly hygroscopic. Being softer and more plastic than NaI(Tl), it can withstand severe shocks, acceleration, and vibration, as well as temperature gradients and sudden temperature changes.

- $\text{CaF}_2(\text{Eu})$  consist of low-atomic-number materials, and for this reason makes an efficient detector for beta particles and x-rays with low gamma sensitivity. It is similar to Pyrex and can be shaped to any geometry by grinding and polishing. Its insolubility and inertness make it suitable for measurements involving liquid radioisotopes. The light conversion efficiency is about 50 percent of that for  $\text{NaI}(\text{Tl})$ . Other crystals such as  $\text{LiI}(\text{Eu})$ ,  $\text{LiF}(\text{Eu})$  can be used to detect thermal neutrons with good efficiency.
- $\text{ZnS}(\text{Ag})$  scintillators are mainly used for alpha particles.  $\text{ZnS}(\text{Ag})$  luminescent powder coatings are adhering on a transparent disc such as Plexiglas. Sensitive areas range between 50 and 100  $\text{cm}^2$ , with thickness of the order of the range of alpha particles. This kind of detector has a very low background.

### 3.5 Semi-conductor diode detectors

Solid state detectors for the measurement of high energy electrons or gamma rays is of great advantage because their densities are much greater compared with gas. The first type of solid state detector, scintillation detectors, has been described in section 3.2. As it has been seen, they are mainly used either for particles counting ( $\alpha$ ,  $\beta$  or  $\gamma$ ), or spectrometry.

One of the major limitations of scintillation detectors is their poor energy resolution, which is about 8% at 662 keV, more than 10% at 1332 keV. As reported in section 3.2, the use of semi-conductor for ionising particle detection results in a larger number of charge carriers than any other detector. This is why semi conductor detectors enable the highest resolution measurements.

Along its path through semi-conductor material, incident ionizing particles create excitation of electrons, which leave the valence band, cross the band gap and reach the conduction band. The resulting vacancies in the valence band are called holes. Excitation process in semi-conductor, which generates electron/hole pairs, is somewhat similar that ions pairs creation in a gas.

If an electric field is applied, electrons of the conduction band as well as holes of the valence band move, and are collected by electrodes. The corresponding pulse depends of the energy lost by the ionizing particle along its path in the semi-conductor material.

The energy expended by the charge particle when creating a electron/hole pair is called the Ionisation energy. Its value is about 3 eV for the most commonly used material (Si or Ge). This is 10 times lower than the energy required for a ion pair creation in a gas filled detector.

It must be emphasized that electron/hole pairs creation always occur in a semi-conductor, due to the thermal excitation. This induces a leakage current, even in the absence of ionizing radiation. A way of reducing the background noise is to cool the detector. This is very usual for gamma spectrometry with Ge diodes.

- Silicon detectors

Silicon detectors are widely used for alpha particles spectrometry. Their advantages are a good energy resolution, good stability, thin entrance window, room temperature operation. The resolution values depend of the size of these detectors: around 10 keV for small detector (few  $\text{cm}^2$ ), lower than 20 keV for a large detector (20  $\text{cm}^2$ ), for an incident 5.5 MeV alpha radiation.

Silicon diodes can also be used for the measurement of beta particles

- Germanium detectors

Germanium detectors are very common for high resolution gamma spectrometry. Planar geometry is preferred for low energy gamma rays (< 400 keV). For such detectors, the volume does not exceed 10 to 30 cm<sup>3</sup>. When larger volumes are needed, for high energy gamma rays for example, Ge detectors can be manufactured in coaxial (cylindrical) geometry.

Because of the small band gap of Germanium (0.7 eV), it is conventional to operate such detectors at liquid nitrogen temperature (77 K). Most of the time the detector and the preamplifier are kept in thermal contact with a dewar.

Resolution values of 0.5 keV can be obtained at 122 keV with a small planar germanium. With a coaxial detector, a common value for 1.3 MeV is 2 keV. In general, the energy resolution with Ge detectors is about a few tens of percent, to be compared with the 5 to 10 % with NaI spectrometers. This is why Ge detectors are always preferred in case of complex gamma ray spectra.

Most of the time, commercial manufacturers specify the relative energy efficiency of a diode. This value is a ratio between the total efficiency of the detector and the total efficiency of a 3" x 3" cylindrical NaI-Tl crystal. Both of these efficiencies are supposed to be determined at the highest photopeak from <sup>60</sup>Co, with a distance of 25 cm between the source and the detector. For low level measurement, relative efficiency of 40% is commonly used, because they appear as a good balance between the efficiency and the cost (about \$ 25 000). The price of electronics (Amplifier, MCA) range between \$5 000 to \$10 000 for a portable battery powered equipment. The relative efficiency of some recent devices can reach 80% or more.

If the emission spectrum of the waste to monitor is rather simple (<sup>60</sup>Co and <sup>137</sup>Cs) for example, NaI LRGS might be operated, since is very sensitive and not expensive (\$ 3 000 \$ for a 3"\*3" commercial NaI probe with preamplifier - \$3000 for the cheapest electronics). However, in spite of its sensitivity, MDA and measurement uncertainty might be higher than those obtained with a Ge.

### 3.6 Statistical aspects

#### *Comments concerning statistical significance of a measurement*

The standard deviation is a measure of the accuracy of an observation. In counting greater accuracy can be achieved only by increasing the total counts recorded. Usually it is required to find the count rate due to radiation above a background count rate.

The detection sensitivity of a measurement system refers to the statistically determined quantity of radioactive material or radiation that can be measured or detected at a preselected confidence level.

Activity measurements often comprise two measurements: one for the background and another for the sample, from which the background has to be subtracted.

#### *3.6.1 Counting Statistics and Background*

The radioactive decay of single atoms is random in time and so the number of particles or photons counted in a given time will fluctuate about an average value. The standard deviation is a measure of the scatter of a set of observations about their average value. If a single count is made over a time the

standard deviation on the count may be taken as the “root Count Square”. Usually it is the counting rate that is of interest and this may be written:

$$C = N/t \pm \sqrt{N/t}$$

Where:

C = counting rate

N = number of counts

t = counting time

The standard deviation is, therefore, a measure of the accuracy of an observation. In counting greater accuracy can be achieved only by increasing the total count recorded. Usually it is require finding the counting rate due to radiation above on a background counting rate. The result must be corrected and counting rate is given by:

$$S = N/t_N - B/t_B \pm \sqrt{(N/t_N^2 + B/t_B^2)}$$

Where:

S = net counting rate

N = number of counts measured

$t_N$  = counting time of measure

B = number of background counts

$t_B$  = counting time of background

When counting very low activity very long counting times may be required to achieve an acceptable statistical accuracy. Under such circumstances it is desirable to choose the most efficient distribution of the time between the source plus background and background measure. The highest accuracy is achieved when:

$$t_N/t_B = \sqrt{k}$$

where k is the ratio of total counting rate to the background rate.

### 3.6.2 *Minimum detectable activity*

The detection sensitivity of a measurement system refers to the statistically determined quantity of radioactive material or radiation that can be measured or detected at a preselected confidence level.

Any activity measurement comprises two measurements: one for the background and another for the sample, from which the background has to be subtracted. In practice, taking into account the quantity of measurements to be undertaken, every test point is submitted to a single and short time measurement. Therefore, it would consider, in relation with the average background:

- The probability to consider the number of impulses as a value belonging to the distribution of both the signal and the background, whereas in reality, it belongs to the background distribution. This probability is called type-one error.

- The probability to reject the number of impulses as belonging to the background distribution, whereas in reality, it would belong to the distribution of both the signal and the background. This probability is called type-two error.
- The maximum error made on the signals from the radioactivity detection, after the deduction of the average background from the indication given by the instrument.

The detection sensitivity of the instrument corresponds to the lowest counting that can be distinguished from the background for a given probability. Statistically, the Minimum Detectable Activity (MDA) can be defined as the measurement value for which the relative uncertainty equals  $\pm 100\%$  at 95% probability level. In selecting suitable instrumentation, it is necessary to define the MDA for a particular instrument and to compare such MDA with the required criteria. Choosing instrumentation with a low MDA is an important factor in the selection process.

Mathematical expression of MDA may vary depending of the probability level required. Examples can be founded in the following standards:

- NUREG 1507
- ISO/FDIS 1929-4: Fundamentals and application to counting measurements by high resolution gamma spectrometry, without influence of sample treatment
- ISO/FDIS 1929-5: Fundamentals and application to measurements used by linear scale analogue ratemeters, without the influence of sample treatment.

In some cases the MDA is given for a probability other than 95%. The MDA levels will be significantly lower than those measured during normal operation and the MDA corresponding to release criteria are generally very small. Measurement designed to validate the required MDA criteria should be undertaken in an area where the background level is sufficiently low. In some cases may be necessary to create a restricted area in the plant with a very low background. The maximum background level may be determined using the above expressions replacing the MDA by the release criteria.

### 3.7 Laboratory equipment

Laboratory methods must be used when in-situ measurements are not available to detect some radionuclides and to obtain a better knowledge of the radionuclides present, especially low energetic or pure beta emitters ( $^{90}\text{Sr}$ ,  $^{63}\text{Ni}$ ) or alpha emitters. Moreover, such analyses are necessary to define typical spectrums and to establish correlations between easily detected nuclides (mainly gamma emitting isotopes, such as  $^{137}\text{Cs}$ ,  $^{60}\text{Co}$ ,  $^{106}\text{Rh}$ ,  $^{125}\text{Sb}$ ...) and “hard to detect” nuclides.

On the other hand, laboratory analysis is required to get information about migration of contamination inside soils or concrete structure.

Laboratory methods are much time consuming and more expensive than direct methods.

The most commonly used radiation detection measuring equipment is also used for laboratory analyses and/or measurement, but usually under more controlled conditions which lower detection limits and greater discrimination among different radionuclides.

Those methods involve the combination of both chemical and instrumental techniques.

### 3.7.1 Alpha activity measurements

Alpha particle measurements on samples can be made, after chemical extraction, with alpha scintillation detectors, proportional counters or semiconductor detectors. The most important laboratory measurements are alpha spectrometry; the others only permit measurement of total activity. There are in the market many devices available to do those measurements.

The main problem is the sample preparation; the samples should be thin to keep the alpha particle self-absorption as low as possible for liquid samples this can be done by simply evaporating the liquid on the measurement plate or by electro-deposition. Thin solid samples are difficult to prepare. In some cases it is necessary attack with solvents the material and to carry out the measurement of liquid. These kinds of measurements are more qualitative than quantitative.

- samples from liquid
  - *total counting* : The total alpha activity is almost exclusively measured on “dried samples” It is extremely important that the salt content of the liquid which has to be measured is as low as possible, in order to avoid self absorption of the alpha radiation. Furthermore, a correction function is applied, which is function of the amount of salt deposited on the plate on which the liquid is dried, expressed in mg/cm<sup>2</sup>. Experience showed that this correction factor is only relatively accurate for low salt contents.
  - *spectrometry*: The salt content of liquids, on which alpha spectrometry has to be applied, must also be as low as possible. A specific extraction is performed, with hexone, in order to remove the alpha emitting isotopes from the salts in the original sample, as soon as salts in this solution are expected. The alpha spectrometry is then achieved on the resulting salt free solution. The efficiency of extraction must be carefully determined, and is an additional source of inaccuracy.
- other samples
 

The measurement of the total alpha activity of solid samples is very difficult because of the possible self-absorption. If a surface contamination of the solid is the unique source of alpha radioactivity, the measurement is then only complicated by the eventual presence of salts on this surface layer. If the alpha contamination is has penetrated in the sample, then the efficiency is low and must be very carefully determined. The measurement of massively contaminated samples seems applicable only in specific cases.
- equipment used
 

The proportional counters permit to processing large quantities of samples in a short time, with relatively good detection sensitivity.

Using grid Ionisation chamber filled with argon and pressurized carries out alpha spectrometry. The counting geometry is  $2\pi$  and, between 4 and 6 MeV, the detection limit is very low. Semiconductors with silicon surface barriers are also used for alpha spectrometry. The crystal thickness reduces the interference with beta or gamma radiation. This detector is very fragile and measurements must be carried out under vacuum conditions to reduce the alpha absorption in air. This equipment can be used at ambient temperature however cooling the detector can reduce the background noise.

The detection limit depends of both, the detector used and the sample to be measured. As an example with a proportional counter and a filter sample the Lower Limit of Detection (as Currie defined) is between 0.005 Bq and 0.06 Bq for 600 seconds and 60 seconds counting time respectively.

For alpha spectrometry the detection threshold is near 0.01 Bq/g of  $^{241}\text{Am}$  for a filter sample and 0.03 Bq/g for  $^{241}\text{Am}$  and  $^{238}\text{Pu}$  for soils samples.

### 3.7.2 *Beta activity measurements*

Laboratory methods are oriented to measure pure or pure beta emitters such as  $^{90}\text{Sr}$ ,  $^{99}\text{Tc}$  and/or low energetic beta emitters such as  $^{63}\text{Ni}$ ,  $^3\text{H}$ ,  $^{14}\text{C}$ .

Methods for analysis of samples containing pure beta emitters require chemical separation. Afterwards the measurement is made with proportional counters or by X-ray spectrometry.

Proportional counters can be used to do low level measurements of global beta emitters with energy > 150 keV. The advantage of this method is the low background achievable with appropriate shielding. The Lower Limit of Detection for a filter sample is below 0.04 Bq for 60 seconds counting time. Specific isotopes, as  $^{90}\text{Sr}$ , can be measured with a Lower Limit of Detection below 0.2 Bq for the same counting time.

Liquid scintillation measurements are often used in the case of liquid samples. The liquid scintillation spectrometer is a well-adapted method for  $^{14}\text{C}$  and  $^3\text{H}$ , and the sample can be mixed directly into scintillation liquid and counted. With the spectrum capability of modern instruments, it is possible to identify the specific beta emitters present when few different emitters are present. Detection sensitivity is very high.

Lower Limit of Detection for both radionuclides is on the order of 0.2 Bq for 60 seconds counting time and 0.02 Bq for 800 seconds counting time.

Extraction nickel from chemical solutions has been described in bibliography. The extraction yield is calculated from the measurement of stable element in the first and the final solution using an atomic absorption method. A rough estimate of  $^{90}\text{Sr}$  can be made from direct high-energy  $^{90}\text{Y}$  beta measurement, but if lower limits are required, a radiochemical analysis should be performed. It should be noted than the process of extraction itself is an additional source of inaccuracy.

For  $^{55}\text{Fe}$  and  $^{63}\text{Ni}$  the detection threshold is below 0.8 Bq and 0.2 Bq for 60 seconds and 800 seconds counting time respectively. Lower Limit of Detection for  $^{90}\text{Sr}$  is lower on the order 0.02 Bq and 0.009 Bq for the same counting times.

### 3.7.3 *Gamma spectrometry*

Gamma spectrometry in laboratory is used to define isotopic composition of materials. The advantage of this method is that a very low detection limit can be reached. In-situ measurements are very much influence by background and shielding is difficult. High purity germanium detectors and Ge-Li detectors are used in the laboratory for precise spectrometry. They have a good resolution and relative high efficiency 20 - 40%.

The detection limit in gamma spectrometry is largely dependent on analysis technique, the external background and the radionuclides that are mixed with the element to identify. For example Lower Limit of Detection for  $^{137}\text{Cs}$  and  $^{60}\text{Co}$  is better than 1 Bq for 60 minutes counting time in several geometries (Petri box or 500 ml Marinelli beakers). These values can be improved using large counting times.

Sodium iodide scintillators can be used in gamma spectrometry; their capacities are lower but are less expensive. They have a good efficiency but a bad resolution. They can be useful to detect few gamma emitters with a wide range of energy.

Table 3.3: **Laboratory Destructive Analyses for Common Radionuclides**

The following table indicates the methods that are most commonly used for usual radionuclides:

Laboratory Method	Radioisotopes
Alpha spectrometry	$^{237}\text{Np}$ , $^{233}\text{U}$ , $^{234}\text{U}$ , $^{235}\text{U}$ , $^{238}\text{U}$ , $^{238}\text{Pu}$ , $^{239}\text{Pu}$ , $^{240}\text{Pu}$ , $^{241}\text{Pu}$ , $^{241}\text{Am}$
Beta counting	$^{90}\text{Sr}$ , $^{99}\text{Tc}$
Gamma or X spectrometry	$^{55}\text{Fe}$ , $^{59}\text{Ni}$ , $^{60}\text{Co}$ , $^{85}\text{Kr}$ , $^{94}\text{Nb}$ , $^{129}\text{I}$ , $^{137}\text{Cs}$ , $^{235}\text{U}$ , $^{237}\text{Np}$ , $^{241}\text{Am}$
Liquid Scintillation	$^3\text{H}$ , $^{14}\text{C}$ , $^{63}\text{Ni}$ , $^{85}\text{Kr}$ , $^{90}\text{Sr}$ , $^{151}\text{Sm}$ , $^{226}\text{Ra}$ , $^{241}\text{Pu}$
ICP/MS	$^{99}\text{Tc}$ , $^{129}\text{I}$ , $^{107}\text{Pd}$ , U, Th, $^{237}\text{Np}$
Mass spectrometry	$^{233}\text{U}$ , $^{234}\text{U}$ , $^{236}\text{U}$ , $^{238}\text{U}$ , $^{238}\text{Pu}$ , $^{239}\text{Pu}$ , $^{241}\text{Pu}$ , $^{242}\text{Pu}$ ,

### References for Chapter 3

- 3-1 "The Health Physics and Radiological Health Handbook". Edited By Bernard Shleien. 1992
- 3-2 "Measurement and Detection of Radiation". Nicholas Tsoulfanidis. 1983
- 3-3 "State-of-the art review on technology for measuring and controlling very low level radioactivity in relation to decommissioning of nuclear power plants". Report EUR 10643 (1986). Hulot M, Chapuis A. M et al.
- 3-4 "Nuclear Radiation Detection". Second Edition. William J. Price
- 3-5 "Optimisation of measurement techniques for very low-level radioactive waste material". Report EUR 13307 (1991). R. Hoffmann, B. Leidenberger
- 3-6 "Monitoring Programmes for Unrestricted Release Related to decommissioning of Nuclear Facilities" Technical Reports Series n° 334 IAEA 1992.
- 3-7 "Radiation Protection Instrumentation and Its Application" ICRU Report 20. ICRU
- 3-8 "An introduction to Radiation Protection". Alan Martin & Samuel A. Harbison. 1979
- 3-9 "Evaluation of Surface Contamination, Part 1, Beta Emitters" ISO Report ISO-7503-1 .1988
- 3-10 "Manual for conducting Radiological Surveys in support of License Termination". NUREG/CR-5849 ORAU-92/C57 N.R.C. February 1993.
- 3-11 Currie, L.A. (1968) A Limits for quantitative detection and quantitative determination. Applications to radiochemistry. Anal. Chem. 40, 586.



## 4 OVERVIEW OF MEASUREMENT METHODS AND APPLICATIONS

The methods used to measure low-level activity materials, equipment or structures can be separated into two main categories: direct measurements (non destructive methods) and indirect measurements (sampling or smear test).

The methods used to measure low level activity material are, in this part, classified into 3 measurement techniques:

- volumetric: activated material, bulk contamination, inaccessible surface contamination;
- surface: inner or outer surface contamination ;
- indirect: smear test and sampling, for determination of activity inside an object.

The techniques described below can be applied *in situ*, in an adjacent lower background area, or in a separate laboratory.

The performance of measurement devices may be regularly checked for quality assurance purposes. A well documented calibration method is necessary for all of the above mentioned methods.

*Note: In some cases, an activity quantification can be done, without measurement, by the means of theoretic calculations (e.g. neutron activation of structures in nuclear power plants).*

### 4.1 Volumetric Measurements

Determination with direct methods of the activity inside a component can only be performed when the emitted radiation reaches the detector. The proportion of the associated  $\alpha$  or pure  $\beta$  emitters needs to be found, to ensure compliance with the release level. Neutron measurement techniques are mentioned in this section. Although they are common in some waste control devices, their application for low level waste is uncommon.

#### 4.1.1 Gamma measurements

Techniques for the detection of gamma-radiation can be divided into the three following categories:

- High Resolution Gamma Spectroscopy (HRGS)
- Low Resolution Gamma Spectroscopy (LRGS)
- Gross Gamma Counting.

The first two methods involve measuring the energy spectrum of the gamma-rays originating in the sample and using specific features within this spectrum to identify and differentiate between gamma-rays from different isotopes as well as to quantify the amount present. As its name suggests, gross gamma counting simply counts the total number of gamma-rays reaching the detector without heed of their energy (although some threshold selection criterion may be applied). In that case, reliable assumptions have to be taken into account, concerning the radiological spectrum of the gamma emitting radionuclides.

The three techniques are now discussed in descending order of resolution and comparison of their detection limits is then made.

Direct gamma measurements can be applied in the field. However, in view to increase the sensitivity performance, direct measurements can be done on-site facilities with reduced background.

#### 4.1.1.1 High Resolution Gamma spectroscopy

The most common form of detector technology used for HRGS is based on crystals of high purity germanium (HPGe). An HPGe detector (usually single crystal p- or n-type coaxial intrinsic germanium) acts as a reverse biased diode, not producing any current, when a high voltage bias is applied to it. It produces a pulse of charge when a gamma-ray is incident upon it; the amplitude of the pulse produced is proportional to the energy deposited in the detector by the gamma-ray. HPGe detectors typically have an energy resolution of between 1.5 and 2.5 keV at 1.3 MeV and are required when the gamma-ray spectrum to be measured is complex, containing many gamma-ray lines from several radionuclides as in the example shown in Figure 4-1; or when a low detection limit is required.

In large waste containers the waste composition and radionuclide content may vary over its volume. To avoid systematic errors, the radiation emission and its transmission through the waste should be measured in several locations over the containers, and the gamma-ray assay instruments can be equipped with multiple detectors or a single detector that is scanned past the container (or the container is scanned past the detector).

Figure 4-1: Typical HRGS Spectrum

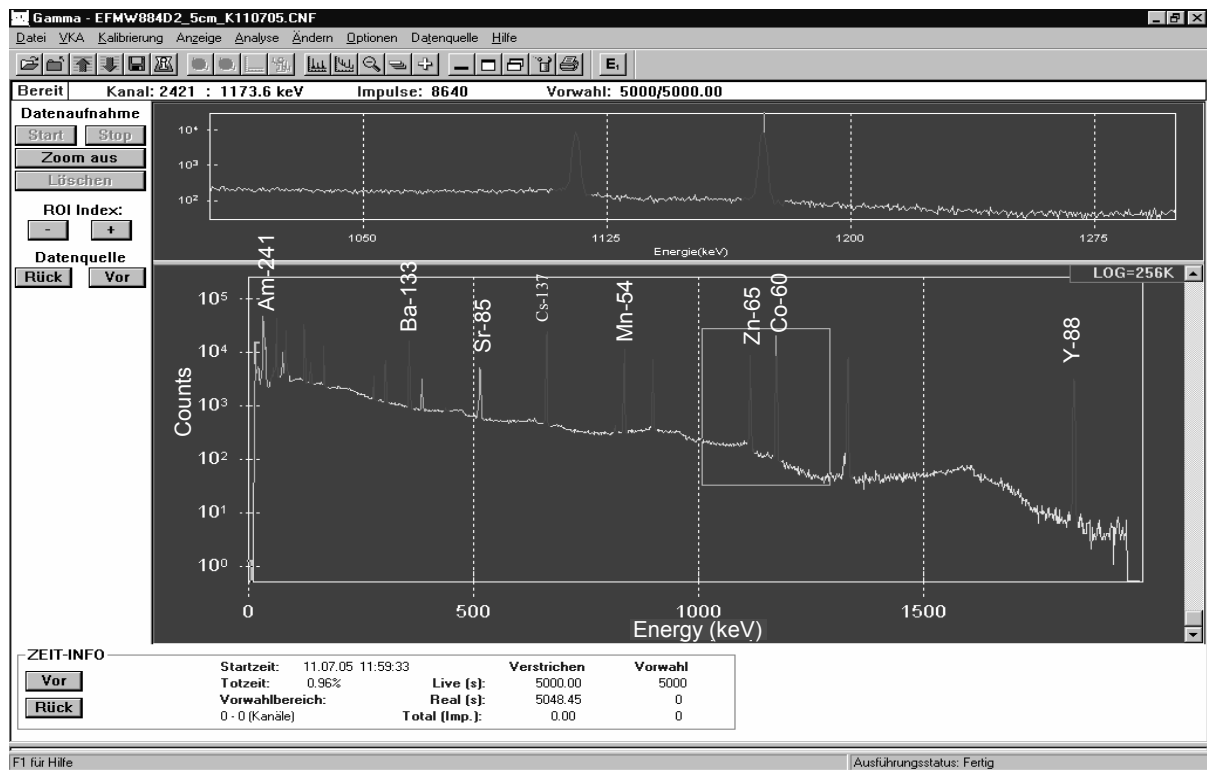

The segmented gamma scanner (SGS) is a common scanning device: in an SGS the waste container is rotated on a turntable while a single detector is scanned vertically to measure the container in a number of discrete slices, or segments (typically 8-20). The container is rotated to even out any radial non-uniformity.

Multiple detector instruments typically use between 2 and 6 detectors, each viewing a single slice of the container while it is rotated on a turntable. The vertical spatial resolution is poorer than a scanning SGS but, because all slices can be measured simultaneously, the total measurement time can be considerably shorter.

The gamma-ray assay system can have its detectors shielded individually or they can all be built into a shielded enclosure to reduce the level of background radiation incident upon the detector(s) from other waste containers in the vicinity, and which would otherwise affect the sensitivity to low levels of activity in the drum being measured.

The gamma spectrum that can be obtained with detectors is usually analyzed by dedicated software: peaks are detected, and analyzed. In some cases, isotopes can be automatically identified. Calibration of detection efficiency enables specific activities of the main isotopes to be estimated from full energy peaks areas. Two kinds of efficiency calibration can be operated:

- calibration with known activity point sources, set out in a scale model, that is similar to the waste to be controlled,
- numeric calibration that can be worked out with calculation codes.

Additionally, energy calibration (i.e. correspondence between energy values and channels) has to be periodically checked with multi-energy emitting isotopes, usually  $^{152}\text{Eu}$ .

An application is described in chapter 5.2.5.

Waste measurement using HRGS is regulated in France by a norm. An ISO Standard is underway.

HRGS can be directly operated in-situ: devices have been operated for concrete wall final control (see 5.2.4 and 5.2.7). Their main advantage is the possibility of measuring large areas (few  $\text{m}^2$ , or more) in a low counting time, with a detection limit below  $1 \text{ Bq}\cdot\text{g}^{-1}$ . The result of each measurement is the average mass (or volume of surface) activity of the part of the wall seen by the detector. This implies geometric assumptions to be taken, for example the depth of the contamination.

#### 4.1.1.2 Low Resolution Gamma Spectrometry

A common example of this type of system uses sodium iodide (NaI) scintillator crystals coupled to a photomultiplier in order to convert the light produced by each incident gamma-ray into an electronic pulse whose amplitude depends upon the energy deposited in the crystal by the gamma-ray. NaI detectors have a much poorer energy resolution than HPGe detectors, but are suitable for use when the gamma-ray spectrum is relatively simple, containing one or a few well spaced lines or a broad energy region is dominated by one isotope. However, they are cheaper and require less maintenance than an HPGe detector (which must be operated at liquid nitrogen temperatures). As NaI detectors can be made larger and have a better stopping power for high energy gamma-rays they can provide a cost effective, improved efficiency-solid angle product over HPGe detectors.

LRGS systems also tend to use multiple or scanned detectors to measure a rotating waste item.

Very high efficiency, low background LRGS assay systems can be produced either by carefully shielding a few detectors close to the measured item or by building multiple NaI detectors into a low background shielded enclosure.

The following spectrum has been acquired in the same conditions as the HRGS spectrum displayed in fig. 4-1.

Figure 4-2: **Typical LRGS Spectrum**

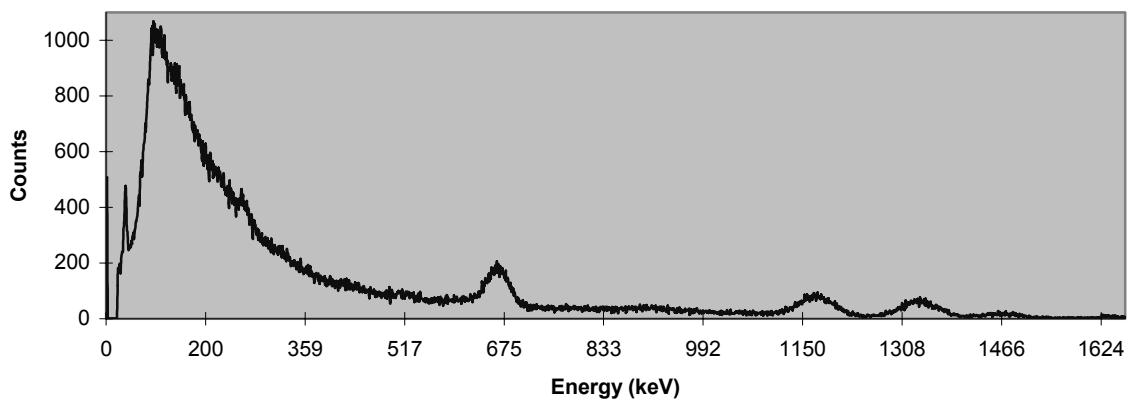

Calibration procedures (efficiency and energy calibration) are similar to HRGS.

Low Resolution Gamma spectrometry can also be operated in the field (see 5.2.2 and 5.2.6)

#### 4.1.1.3 - Gross Counting and dose rate

Gamma probes (Ionisation chambers, Geiger-Müller counters, mainly scintillators) are commonly used. The result is often expressed in counts per second and a conversion factor is applied to obtain an estimated dose rate ( $\text{rad}\cdot\text{h}^{-1}$  or  $\text{Sv}\cdot\text{h}^{-1}$ ), or an activity concentration value ( $\text{Bq}\cdot\text{g}^{-1}$  or  $\text{Bq}\cdot\text{cm}^{-3}$ ). Due to their poor sensitivity to gammas, gas counters are rarely used in very low level measurement devices. Basically, scintillation detectors are more sensitive. On the other hand, they are also sensitive to the background. Therefore, to optimize their use, it is advisable to locate them in a low background environment.

The irradiation values provided by these probes may be used to obtain the specific or surface activity by applying correlation functions, established either by calculation, or by a calibration campaign.

Uncollimated health physics gamma and dose rate monitors are generally limited in their capability for free release monitoring because they are unable to discriminate against background.

An example of instrumentation using gross gamma counting technique consists of an enclosure with walls made from a plastic scintillator material into which an item of waste is placed for measurement. Gamma-rays emitted from the waste item are detected in the walls where the pulse of light produced by each event in the scintillator detection is measured by a photomultiplier. The total count rate (of pulses above a certain energy threshold) produced in all of the walls of the enclosure is then used to determine the total activity of gamma-emitting radionuclides present. Because there is no energy information, the calibration of this type of device relies on the mix of radionuclides being reasonably

constant for all of the waste measured. Its main advantage is its high detection efficiency, which enables low detection limits in short measuring times. This kind of detectors has been widely operated for release measurements (see chapter 5.2)

In case of low release levels, gamma gross counting scintillators might be impractical to measure the activity of naturally irradiating material, such as concrete. Signal due to contamination can hardly be discriminated from the natural background and its fluctuation. As a matter of fact, gamma dose rate in concrete buildings can range between  $80 \text{ nGy}\cdot\text{h}^{-1}$  to  $200 \text{ nGy}\cdot\text{h}^{-1}$ . Moreover, in the same building, this background is not stable, and fluctuations can rise 50% or more. In such cases, if the release level is very low, it is advisable to operate a device that will discriminate the artificial radioactivity from the natural fluctuating radioactivity, such as gamma spectroscopy.

#### 4.1.2 Neutron Measurements

- passive neutron measurement

Passive neutron measurement techniques are not generally applicable to free release measurement problems because, for the relevant isotopes, the release limit is set by the alpha emission rate which is much higher than the neutron emission rate : Neutron emission arises from spontaneous fission, from  $(\alpha,n)$  reactions following alpha decay or from delayed neutron emission by fission products following spontaneous fission.

For example, consider a 200 litre drum containing 200 kg plutonium contaminated material (PCM). For reactor grade Pu, the  $0.4 \text{ Bq}\cdot\text{g}^{-1}$  free release limit would allow just  $0.16 \mu\text{g}$  Pu in such a drum. Its neutron emission rate would be  $\sim 3.8 \times 10^{-5}\cdot\text{s}^{-1}$  or one neutron every 7 hours. The best passive neutron detection limits for such drums are now  $\sim 0.5 \text{ mg}$ , using sophisticated installed equipment.

For uranium waste streams the neutron emission rate per g is lower than for Pu but the alpha emission rate per g is much lower. The  $0.4 \text{ Bq}\cdot\text{g}^{-1}$  limit in a 200 kg, 200 litre drum is now equivalent to  $0.93 \text{ g U}$  for 5% enriched material. With a neutron emission rate of  $0.12 \text{ s}^{-1}$ , this is practically undetectable by passive neutron counting.

- active neutron interrogation

Active neutron devices comprise a neutron source (usually a DT tube producing 14 MeV neutron flux), which is fired into a measurement chamber in short pulses (order of milliseconds) at the sample to be measured. The configuration of the measurement cell ensures the fired neutrons to be thermalised by polyethylene before striking the sample. The thermal neutrons striking the sample will cause fissions in any fissile material present resulting in the production of fast neutrons.

The measurement chamber is enclosed by walls of  $^3\text{He}$  thermal neutron detectors clad in a layer of polyethylene and an outer layer of cadmium. The fast neutrons produced from fissions of any fissile material will be able to penetrate the cadmium passing into the polyethylene layer where they will be thermalised and subsequently detected by the  $^3\text{He}$  detectors. As the fired neutrons are pulsed quickly, the presence of any fissile material can be determined by scrutinizing the relationship between time after firing neutrons and the number of detected neutrons.

Commercially available systems can be used to quickly measure crates of drums for  $^{235}\text{U}$ . Generally use of this technique is most applicable where a bulk measurement of a large mass

or volume of material is required. The technique is able to measure Uranium down to release levels. As this is a total fissile measurement, without Pu/U discrimination, free release would need confirmation that no Pu could be present.

Active neutron interrogation requires the contaminant to be quite well known, i.e. the nature and the part of the fissile isotopes. Moreover, the material of the waste can greatly influence the results of the measurement, especially if neutron absorbers (Chloride for example) are likely to be contained. This method requires also a neutron source (neutron generator or neutron emissive isotope), and many neutron counters. Hence it is not simple to operate and is rather expensive. To conclude, this technique is theoretically applicable, in certain cases, but has not been operated for release level waste control yet.

## 4.2 Surface Measurements

These measurements either consist in placing the detector of a counting device in front of the object or passing the object in front of the detector.

The most basic method to detect surface contamination is undoubtedly the use of portable survey meters directly on the walls or equipment items. These include:

- gas-filled counters (Ionisation chambers, proportional counters, Geiger-Müller counters);
- scintillation detectors.

Measurement of surface activity using  $\alpha$  or  $\beta$  probes is possible only very close with the measured items (see chapter 5.2.3, and 7.6). Most detectors provide a result expressed in counts per second, which must then be converted to usable physical quantities, generally  $\text{Bq}\cdot\text{cm}^{-2}$ . The “cps-surface activity” conversion factors are generally established by the manufacturer on the basis of simple calibrations. These factors depend on the radiation energy – notably for  $\beta$  emitters – and the predominant radionuclides in the activity spectrum must therefore be known.

Surface measurement makes it possible to measure the contamination resulting from the main radionuclides emitting alpha, beta gamma radiation. However, especially in the case of portable devices, it is difficult or impossible to measure low energetic  $\beta$  or no  $\beta$  radioisotopes such as  $^3\text{H}$ ,  $^{14}\text{C}$ ,  $^{55}\text{Fe}$ ,  $^{59}\text{Ni}$ ,  $^{63}\text{Ni}$ .

Evaluation of the surface contamination is defined in the ISO norm 7503-1 and 7503-2. In order to be consistent with this norm, detectors efficiencies that are given below will be defined as follows:

$$\text{efficiency} = \frac{\text{net count rate}}{\text{surfacic emission rate of the source} \times \text{probe surface}}$$

This efficiency is usually called  $2\pi$  efficiency.  $4\pi$  efficiency is obtained by dividing it by 2.

The size of surface  $\alpha$  and/or  $\beta$  contamination monitor range between some tens of  $\text{cm}^2$  and some thousands of  $\text{cm}^2$  (large area floor monitors)

### 4.2.1 Alpha measurements on surface

Because alpha particles suffer continuous energy loss in matter and have a finite range (of a few cm in air), their detection requires successful transmission through the emitting contaminant material,

through the intervening air gap, through the thin entrance window and into the detector itself. They must enter the detector with sufficient residual energy to be detectable above a threshold amount, set to discriminate against noise and perhaps beta particles.

Alpha detectors are designed to have thin entrance windows and to operate with low thresholds and provide low backgrounds. Their efficiency of detection depends on these design parameters and on the distance from the (contaminant bearing) surface. Such a detector can typically detect alpha contamination to the  $0.04 \text{ Bq}\cdot\text{cm}^{-2}$  limit in  $\sim 4$  seconds, where a smaller detector would take longer (80 seconds for a  $5 \text{ cm}^2$  detector).

Due to the short range of  $\alpha$  emission energies (typically between 4 and 7 MeV), detection efficiency for  $\alpha$  emitting isotopes does not vary (around 10%).

#### **4.2.2 Beta measurements on surface**

The detection of beta particles has many of the features of alpha particle detection. In particular, all detectors used to monitor beta actively suffer to some extent from a reduced sensitivity to low energy beta particles due to absorption in the detector threshold set to avoid system electronic noise.

Care must be taken to allow for the effect of beta backscattering which occurs preferentially for heavy surfaces and for angles close to the normal. For plastic, aluminum, steel or tantalum the backscatter is circa 5%, 25%, 45% and 70% respectively.

Beta measurements are also affected by backgrounds due to cosmic rays or to the materials intrinsic to the detector itself and especially due to ambient gamma radiation levels. Typical background levels and the effect on measurement times are given in Table 4.2. The times are generally somewhat longer than for alpha measurements, achieving an LLD of  $\sim 0.4 \text{ Bq}\cdot\text{cm}^{-2}$  in a few seconds for a  $0.1 \mu\text{G}\cdot\text{h}^{-1}$  gamma background. Note that, in higher background conditions, systematic variations in the ambient background rate will effectively raise the observable limit of detection for true beta surface contamination (see table 3.2). Longer and more careful measurements will be required. It should also be remembered that when using a ratemeter, the effective counting time is fixed at twice the ratemeter time constant

- **Proportional counters**

Depending on the energy of the emission, and on the detector,  $2\pi$  detection efficiency range between 60% ( $^{90}\text{Sr}$  or  $^{106}\text{Ru}/^{106}\text{Rh}$ ) and around 40 % ( $^{137}\text{Cs}$ ) less than 30 % ( $^{60}\text{Co}$ ). Table 4.2 shows the minimum time to detect  $0.4 \text{ Bq}\cdot\text{cm}^{-2}$  and  $0.04 \text{ Bq}\cdot\text{cm}^{-2}$ , with the gamma background ranging from  $0.1$  to  $10 \mu\text{Gy}\cdot\text{h}^{-1}$ . The background counting time ( $t_b$ ) is assumed to be the same as the measurement counting time ( $t$ ). Actually, this does not lead to a precise knowledge of the background if  $t < a$  few seconds. However, this is a current practice. The values have been calculated for proportional counters. The efficiency is assumed to be 50%, with a detector surface of  $200 \text{ cm}^2$ .

Table 4.2 **Background Effect Due to Ambient Gamma Radiation (Gas counter)**  
**Assumptions: efficiency = 50% - detector surface = 200 cm<sup>2</sup>**

Ambient Gamma Radiation ( $\mu\text{Gy}\cdot\text{h}^{-1}$ )	Resultant Background <sup>1</sup> (counts $\cdot\text{s}^{-1}$ )	Minimum Time to Detect 0.4 Bq $\cdot\text{cm}^{-2}$ (S=20 counts $\cdot\text{s}^{-1}$ ) at 95% Confidence (s)	Minimum Time to Detect 0.04 Bq $\cdot\text{cm}^{-2}$ (S=2 counts $\cdot\text{s}^{-1}$ ) at 95% Confidence (s)
0.1	5	0.75	45
0.5	25	2.4	200
1	50	3	400
5	250	20	2 000
10	500	40	4 000

- Scintillation detectors

Table 3.3 shows different Minimum Detectable Activity (MDA), for two scintillation probes under different conditions:

Table 4.3. **Experimental MDA**

	Detector		Useful area	Background cps	4 $\pi$ efficiency measured %	Reference emitter	Counting time (s)	MDA Bq/cm <sup>2</sup>
Probe 1	Dual	ZnS+plastic	49 cm <sup>2</sup>	3.5	30	<sup>90</sup> Sr+ <sup>90</sup> Y	1	0.67
Probe 2	Beta	Plastic	100 cm <sup>2</sup>	7.9	38	<sup>90</sup> Sr+ <sup>90</sup> Y	1	0.41
Probe 1	Dual	ZnS+plastic	49 cm <sup>2</sup>	3.6	35	<sup>90</sup> Sr+ <sup>90</sup> Y	10	0.19
Probe 2	Beta	Plastic	100 cm <sup>2</sup>	7.8	21	<sup>90</sup> Sr+ <sup>90</sup> Y	10	0.12

As it can be seen, to obtain release level, these probes must be used with digital ratemeter and counting time should be 10 seconds. However, these values are calculated in the most favorable case, because  $\beta$  emissions of <sup>90</sup>Sr/<sup>90</sup>Y are energetic ( $E_{\beta\text{max}} = 2.26$  MeV). We must keep in mind that in the case of <sup>60</sup>Co, MDA might be two or three times higher. This is due to the low efficiency of detectors to the less energetic  $\beta$  emissions of <sup>60</sup>Co ( $E_{\beta\text{max}} = 320$  keV). Usual  $2\pi$  efficiencies for <sup>137</sup>Cs, <sup>60</sup>Co, <sup>14</sup>C are respectively 40%, 30%, 14% with a  $\beta$  probe. With a  $\alpha + \beta$  probe, efficiencies are lower, due to the attenuation due to the ZnS  $\alpha$  detecting layer: 24% for <sup>137</sup>Cs, 10% for <sup>60</sup>Co. These values may vary from one detector to the other. Low energetic  $\beta$  emitting radionuclides, such as <sup>3</sup>H, are not detected by most of beta detectors. Windowless specific detectors may be used for that purpose.

In many cases suppliers indicate detection limits lower than they might be. In practice they can not be achievable because:

- Background levels are higher.

<sup>1</sup>

This ignores the contribution from residual and cosmic backgrounds. In many detectors this is roughly equivalent to the background count rate from an ambient gamma radiation level of 0.1  $\mu\text{Gy}\cdot\text{h}^{-1}$ .



- Efficiency is lower due the distance between detector and surface being higher than between detector and source when it is calibrated.
- Interference with other emitters.
- Time constant of the ratemeter is not well matched to the measurement optimum.
- Laboratory conditions are different than real operation

#### **4.2.3 Alpha and Beta detection**

Alpha and beta surface measurements can be simultaneously performed with the same device. Most of the gas filled counters used for surface measurement are proportional counters, because they can discriminate between these two kinds of radiation (see chapter 3.3.3). Dual alpha beta scintillation probe can also gives the operator the possibility to detect  $\alpha$  or  $\beta$  with only one probe, which is equipped with a double scintillator (see table 4.3). The electronic discrimination between alpha and beta is dependent on the pulse width and allows excellent separation. A switch allows solely alpha, beta, or both alpha and beta to be measured.

$2\pi$  alpha efficiencies are lower then energetic  $\beta$  efficiencies, typically 30%. But, due to a lower background, MDA is usually lower. For a 100 cm<sup>2</sup> area detectors, MDA might be lower than 0.1 Bq·cm<sup>-2</sup> in a 5s counting time.

#### **4.2.4 Gamma measurements on surface**

In some case, where large concrete surfaces or soils have to be monitored to low levels for unrestricted release, gamma spectrometry might be operated (see chapter 3.5). This implies knowing ratios between  $\gamma$  and non  $\gamma$  emitters. However, regarding the measuring times, this method is not advisable on surfaces area less than 1m<sup>2</sup>, which has to be compared with the averaging area accepted by the national authorities.

Gamma gross counting can also be operated, either with plastic scintillators, or with more efficient inorganic scintillator such as NaI(Tl). These scintillators are used with scalers or ratemeters.

#### **4.2.5 Alpha and Beta measurements on internal surfaces**

Contamination monitoring of the internal surfaces in tanks, pipes and equipment is an especially difficult measurement problem due to the difficulties of access and of keeping a constant scanning distance from the internal surfaces.

##### *4.2.5.1 Associated gamma radiation measurement*

A technique which can be used to measure beta activity when covered with attenuating material is to infer the beta activity from a gamma measurement. Gamma radiation is more penetrating than beta. Often, a beta emitter has an associated gamma emission or a daughter product which is gamma a emitter. If this gamma radiation can be measured, then the beta activity can be determined.

If the material can be accurately fingerprinted from the origin of the material or the operations which were performed in the building being decommissioned, then this provides another method for determining the beta activity. For example, <sup>90</sup>Sr beta activity can be inferred from the <sup>137</sup>Cs gamma activity when a reactor is being decommissioned, because in many circumstances, <sup>137</sup>Cs is produced at the same rate as <sup>90</sup>Sr.

#### 4.2.5.2 *Direct detection*

Cylindrical thin walled Geiger detectors have been deployed inside pipes for beta detection, but the Geiger wall thickness has generally limited the detection of low energy beta particles and so excluded detection of some isotopes. Thin plastic scintillators have been used successfully as beta detectors and measurement times of 20 and 150 seconds to detect to an LLD of  $0.04 \text{ Bq}\cdot\text{cm}^{-2}$  have been demonstrated for gamma background dose rates of  $0.1$  and  $1 \mu\text{Sv}\cdot\text{h}^{-1}$  respectively. In some other cases, however, some problems were noticed: fragility of the probe, low efficiency, distance between the detector and the surface to be measured not precisely adjusted.

Alpha detectors tend to be more delicate and hence difficult to use. ZnS probes have been used successfully for this purpose and other alpha detectors have been proposed but all suffer from delicacy and the risk of detector contamination.

In the case of U or Pu, gamma spectrometry might be used to quantify low levels of  $\alpha$  contamination. For example, the 185 keV emission of  $^{235}\text{U}$  can be used to quantify  $^{235}\text{U}$  activity, and evaluate U contamination if the enrichment is known. This kind of measurement is widely operated in U enrichment facilities. The detection limit can reach  $1 \text{ Bq/g}$  in case of homogenous waste.

#### 4.2.5.3 *Air ionisation measurement*

Alternative methods have been demonstrated which avoid some of the above disadvantages. The most successful of these is the direct measurement of the ionisation of the air in the pipe by alpha contamination. Full range alpha particles can produce an ionisation current in air of  $12 \text{ fA}\cdot\text{Bq}^{-1}$  and this can be measured either directly by passing an anode wire up the centre of the pipe which is itself used as a d.c. ionisation chamber, or by passing the air through a flow through ionisation chamber. The Ionized Air Counter method is highly sensitive and can measure the equivalent of a few Becquerel's in a 2m long pipe in 30 seconds - equivalent to  $\sim 0.001 \text{ Bq}\cdot\text{cm}^{-3}$ . The results depend somewhat on the pipe diameter, the flow rate and the pipe length and a simple calibration for the conditions is normally applied.

### 4.3 **Indirect Measurements**

Indirect measurement methods are used as a complement and sometimes as a substitute to direct measurement methods. Indirect measurements are used when the ionizing radiation from contamination inside or on the surface of the subject considered for release does not reach detectors positioned close to the subject or if the attenuation of the ionizing radiation from embedded or hidden contamination makes precise estimations of the contamination levels difficult. Indirect measurements are also used to give estimates of the ratio between radionuclides which are easy and difficult to measure, respectively with direct measurement methods. Examples of this are when the contamination consists mainly of low energy beta emitters or alpha emitters on surfaces which are difficult to access or when the contamination consists of radionuclides embedded in the material and when these radionuclides do not emit high energy photons.

For large areas such as floors and walls with a low risk of being contaminated above the release levels a statistical sampling method can be applied to assure that contamination has not migrated into the surfaces. This is only needed when the radionuclide composition is such that only radionuclides which can not be detected with direct measurements are dominating in the considered material.

### 4.3.1 *Sampling Techniques*

Measurement by sampling is generally used when all other methods are impossible or in a view of comparison. Radiochemical and/or radiophysical analyses can then be carried out on the specimen taken. These analyses are carried out either directly on the specimen or after treatment (dissolution, separation, etc.). This is the only method which makes it possible to make an inferred measurement of low concentrations of, or embedded radioisotopes such as  $^3\text{H}$ ,  $^{14}\text{C}$ ,  $^{55}\text{Fe}$ ,  $^{59}\text{Ni}$ ,  $^{63}\text{Ni}$  and  $^{99}\text{Tc}$ .

Generally speaking, the main areas in which it can be applied are:

- assessing the radiation of an entire component, in activity per unit mass or area, prior to a process or treatment,
- measuring the radioactivity of a material following a treatment process (melting of dismantled products, crushing waste from the demolition of engineered structures after cleaning of structural concrete, decontamination of complex shaped equipment, etc. ),
- verifying that contamination has not migrated into certain materials such as concrete,
- determining the radioactivity of radionuclides which are difficult to measure with other methods, or determining the ratio of these radionuclides to radionuclides which are more easily measured on the outside of a subject such as  $^{60}\text{Co}$  or  $^{137}\text{Cs}$ , etc.

To assess the radionuclide content of an entire component, representative samples must be taken. The contamination profile inside the component must be considered when taking these samples must be considered as for example induced radioactivity will give a different profile than migrated surface contamination. Normally core samples should be taken with separation of material from different depths depending on the contamination situation. The size and number of core samples must guarantee a representative selection.

### 4.3.2 *Smear Tests*

Smear tests are similar, in the physical and chemical treatment they receive after they have been taken, to sampling measurements. They are more particularly used when the loose surface contamination has to be separated from the total surface contamination or when the contamination essentially consists of loose surface contamination. The standard operating procedures for smear tests take account of the substrate and of the surface to be treated. With smear tests low concentrations of loose contamination can be measured. The minimum detectable activity concentration depends on the fraction transferred from the surface to the smear, the measuring equipment or method, and the radiation emitted from the smear. If the loose contamination can be transferred only to the outer surface of the smear or if the smear can be inserted in a liquid scintillator then all the radionuclides in question can be measured otherwise only high energy beta/electron emitters can be measured at low concentrations. Special care should be exercised to make the taking smears reproducible considering the size of the smeared surface (normally 100 cm<sup>2</sup>), the pressure when taking the smear, the existence of other types of contamination such as water, dust or oil as this effects the transfer factor and that the measurements are performed in stable low background conditions. For example the transfer factor from the contaminated surface to the smear ranges from 0.01 to 0.99 with 0.1 considered as the appropriate factor for dry smear tests.

#### 4.4 Application aspects of the measurement techniques

During the decommissioning of nuclear installations, various types of materials, such as metals, concrete, wood, etc., have to be released which are considered to be free of activity or contamination. Unrestricted use of these materials may be permitted if the residual surface contamination and/or the residual specific activity levels are below limits imposed by the licensing authorities with regard to radiological risks. In order to prove compliance with these limits, the residual surface contamination or specific activity levels have to be monitored on every single piece of material that is removed from a nuclear installation or a controlled area. Less extensive monitoring can be performed only if it can be proven that the contamination situation is similar for a whole batch with the same origin and having experienced the same treatment, in this case it must be proven from the measurements that all tested parts in the batch is well below the limits. If the origin is known then it might be possible to exclude that the material considered for unrestricted use is contaminated with radionuclides which are difficult to measure, in this case it should be acceptable that the measurement procedures used will not facilitate detection of these radionuclides.

##### 4.4.1. Direct measurements of alpha emitters

Several practical problems may significantly influence one's ability to conduct adequate direct measurements of alpha emitters on/in materials and/or in buildings in the field.

These problems are partly related to the physics of the alpha particles. Compared to beta and gamma radiation, alpha particles emitted by a radioactive source have a short range. This range varies with the particle's energy, but is of the order of a few centimeters in air.

As a result of this very short range of the alpha particles in air and of the fact that alpha particles are totally absorbed when passing through quite thin layers of material, direct measurement of alpha emitters is a problem or is not suitable on:

- rough or uneven surfaces with cracks;
- a surface covered with a shielding layer like paint, grease, oil or corrosion products;
- difficult geometry's like bent surfaces, corners, edges or inside tubes, etc.;
- absorbing or porous material.

When monitoring alpha emitters, the detector should be placed as near to the surface to be measured as possible (a few mm), due to the short range of the alpha particles and, in addition, to the fact that this range is effectively reduced by the detector window. As such, great care must be taken to prevent any contamination of the detector window.

A common problem with thin-window detectors is their fragility and the ease to damage (puncture) the thin window itself. To avoid such damage to the very thin detector window a grid, a frame with small openings, is placed over the window, which results in a reduction of the detector efficiency, however.

In the case of scintillation detectors, special attention has also to be given to important magnetic fields. The magnetic field deflects the electron pathways inside the photomultiplier, reducing the gain and reduces the alpha generated pulses to below the counter threshold.

To minimize monitoring errors, detector calibration must be carried out using standards of the radionuclides to be measured and presenting configurations as encountered in normal field conditions (distance, geometry, surface material with comparable self-absorption characteristics).

Direct alpha measurements for unconditional release are very low level measurements, in which the levels are sometimes in the order of the detection limit of the detector. When making this kind of measurements, the detector should be moved extremely slowly over the surface, resulting in extremely time consuming and expensive operations. With some of the equipment used, demonstrating an alpha contamination on metal surfaces that have been decontaminated requires a minimum measurement time of about 6 to 10 seconds per 50 cm<sup>2</sup>. Technicians having extensive experience in this field must make the interpretation of the measurements.

#### **4.4.2 Direct measurements of beta emitters**

The same comments as for direct alpha measurements apply to direct beta measurements with a few exceptions.

The range of beta particles is in most cases much greater than the range of alpha particles. As a matter of fact, the range of fast electrons in air range from 10 cm ( $E\beta=100$  keV) to 3.5 m ( $E\beta = 1$  MeV) or more for energetic beta. The limiting values for beta contamination are often a factor 10 higher than the corresponding values for alpha contamination. This will make beta measurements easier to perform than alpha measurements.

Beta energies are varied, ranging from about 100 keV to several MeV (usually below 2 MeV), which induces different efficiencies.

Beta detectors are more influenced by background radiation than alpha measurements. In case of high gamma background, this will make beta measurements more difficult to perform than alpha measurements. However, in the case of release levels, high gamma backgrounds are not common. Moreover, if proportional counters are used, this background can be easily measured and subtracted from the raw signal of the detector.

Beta measurements can in most cases be performed faster than alpha measurements, because:

- the release levels of  $\alpha$  contamination are lower.
- the measurements are to be performed very close to the contaminated surface.

A problem associated with beta measurements, which sometimes need to be considered is beta backscatter. The atomic number of the underlying material has a pronounced influence on the fraction of electrons which are backscattered. The fraction of backscattered electrons rises of about 25% from Aluminum, 45% from steel, and more than 60% from heavy metals like tungsten. This leads to a falsely high reading from measuring instrument. Modeling techniques, such as the MCNP calculation code, can be used to more accurately calculate the effect of beta backscattering.

#### **4.4.3 Gamma measurements**

When gamma gross counting or gamma spectrometry is performed on a large area, it is impossible make a difference between an averaged surface contamination and a punctual irradiating hot spot. For example, a 3m \* 3m concrete wall, uniformly contaminated (2Bq/g - <sup>60</sup>Co) on the two first centimeters will generate, at 1.5 meters, the same gamma flux than a punctual 1 MBq hot spot located in one of its corner. Hence, gamma measurements averaged on large areas, or uncollimated, might hide punctual hot spots.

Gross gamma counting might be difficult on naturally emitting material, such as concrete, because of the natural gamma background. In concrete buildings, this gamma background range between around

70 nGy/h and 200 nGy/h, sometimes more. In the same building, fluctuations of more than 50% have been observed from one room to the other. This may affect the accuracy of gross gamma counting's. In case of low release levels, gamma spectrometry that discriminates between natural and artificial activity might be preferred.

#### ***4.4.4 Indirect measurements of alpha and/or beta emitters***

Indirect methods rely on taking representative samples and making measurements on these samples. As only samples are taken, this method will not give a complete presentation of the contamination situation: the more representative you want to be, the more samples are to be analyzed, the more expensive it will be. How representative the samples are must be estimated by qualitative methods. Also these methods are very time consuming and technicians having extensive experience in this field must make the interpretation of the measurements.

Specifically for metal components, where inaccessible surfaces create difficulties when applying direct measurements techniques, melting is a very attractive technique on industrial scale for characterisation and indirect measurement of alpha and beta emitters. It is well known that melting of metals in an induction furnace gives a product in which the remaining radioactivity is well homogenized. The same results can be achieved in other kinds of furnaces, by addition of chemical compounds. In such case, it is accepted that a rather small sample from a charge of metal is representative for the whole charge since any remaining radioactivity content is homogenized over the total mass of the ingot.

It must also be observed that radioactive contamination incorporated into superficial layers might migrate to the surface, especially after decontamination with some chemical agents (this process is often called sweating). For such cases, measurements of surface contamination should be performed a few days after the decontamination.

#### ***4.4.5 In-situ Gamma Spectrometry (ISOCS)***

An ISOCS system consists of the following major components:

1. An "ISOCS Characterised" Germanium Detector.
2. A versatile set of Shields and Collimators on a Cart.
3. A Portable Spectroscopy Workstation.
4. A Laptop with PC running software, e.g. Genie-2000.
5. ISOCS In Situ Calibration Software.

Figure: 4.3 **Isocs In-situ Gamma Spectrometer**

The ISOCS Detector,  
Cart,  
and Shield Components.

Configured for  
Soil/Floor Analysis.

Configured for  
Samples  
in Small Containers.

Can also Count  
Large  
Samples in  
Marinelli Beakers.

A brief description of each of these can be found in the following sections.

### **The ISOCS Detector and Shield**

The detector, shield system, and mounting cart, shown in Figure 4-3, are the key elements of an ISOCS system.

#### ***The Detector***

While the typical ISOCS detector will be a coaxial Germanium with a relative efficiency of 30-80%, the design of the shield allows selecting the type – including Broad Energy (BEGe), Low Energy (LEGe) and Reverse Electrode (REGe) detectors –and size best suited to the specific needs of the intended application. The most versatile detector is a BEGe detector, which give the highest efficiency at low energies, while still retaining excellent performance at high energies. For greatest flexibility, the detector should be mounted in a remote detector chamber (RDC) cryostat and be equipped with a Multi Attitude Cryostat (MAC) or Big MAC Dewar. These Dewars have the ability for the detector to be operated at any attitude or angle with no LN spillage or reduction in LN capacity. The RDC allows the back-shield to be used, reducing interfering radiation. The MAC is smaller and has a two day LN holding time, while the Big MAC is the most common choice since it has a five day holding time. Once a detector is selected, it is fully characterised by Canberra using a combination of source measurements and MCNP calculations.

#### ***The Shield***

The complete shield package includes both 2.5 cm (1 inch) and 5 cm (2 inch) lead shield assemblies. Each features:

- Modular design for ease of handling and reconfiguration.
- Cast aluminium exterior with baked epoxy coating to simplify decontamination.

- 30°, 90°, and 180° collimator assemblies to minimize interfering radiation and limit the field of view.
- 0° shield for background measurements, and to make the shield into a closed sample counting chamber.
- Back shield for use with RDC detectors to reduce interfering radiation from the behind the detector.

In addition, as shown in Figure 1, the two shield sizes may be combined into a single shielded counting chamber for field assay of small packaged samples.

### ***The Cart***

The cart to which the detector and shield assembly are mounted is used for both moving the ISOCS system around the site, and as amounting base when it is being used for sample assay. As shown in Figure 1, the cart provides both the normal lower mounting position for the detector/shield, and an upper position for one meter in situ ground counting. It is very easy to move the detector and shield between the two positions.

The pivoting detector-holder mechanism provides the ability to easily rotate the detector and shield o ANY desired angle at either of the vertical positions, allowing the detector to be quickly “aimed” at objects of essentially any size, shape, or location.

The detector holder also includes a battery operated laser aiming device o aid in accurately aligning the detector with the object being assayed. This is particularly useful for samples at some distance from the detector, such as overhead pipes.

### ***The Portable Spectroscopy Workstation***

The battery-powered Digital Signal Processor allows laboratory quality measurements in the unfriendly temperature extremes and wide dynamic countrate ranges commonly encountered by in situ users. A multi channel analyzer (MCA), mated to a note-book PC, serves as the spectroscopy workstation for ISOCS. For in situ assays it offers several major benefits:

- Lightweight compact design.
- Long operating life [full workday] on a single battery.
- Complete laboratory grade digital signal processing spectroscopy front end:
  - Detector HVPS.
  - Signal gain.
  - Digital gain and zero stabilisation.
  - 16,384 channel ADC and memory.
  - Digital oscilloscope for accurate pole zero adjustment
- Computer control of all operating parameters, insuring maximum accuracy with a minimum of effort on the part of the operator.

The net result is uncompromising spectroscopy quality in a small, lightweight package ideally suited to field use.

### ***Genie-2000 Software***

The laptop PC which controls the system is under the supervision of the Genie-2000 software package. With it, all of the capabilities of a laboratory based spectroscopy system –including the



Gamma Acquisition and Analysis Window and all Gamma Analysis applications –are available for the in situ user. On top of this, the user can add PROcount, a simple fill-in-the-blank counting procedure package for performing routine ISOCS operations. Using PROcount’s step-by-step procedures, the operator is shielded from the intricacies of the computer, allowing full concentration on the job at hand. This insures more consistent results and greatly reduces the opportunity for procedural errors. While PROcount makes ISOCS easier to use, it in no way limits the system’s capabilities. Standard PROcount procedures are provided for all needed system operations, including:

- Routine Sample Assays.
- Background Counts.
- Energy and Efficiency Calibrations.
- System Quality Assurance.

There is also a password-protected facility for customizing these standard procedures, defining new sample types and geometries, setting up special sample information data entry screens, and building custom analysis sequences and reports.

### ***ISOCS Calibration Software***

Accurate efficiency calibration is a must for any system being used for sample assay. Traditionally this has meant a major investment in the purchase (and later disposal) of a variety of calibration sources plus days of calibration time and effort.

The calibration of an ISOCS system is a three step process:

1. Determining the response function of each specific Ge detector, i.e. detector characterization.
2. Creating a series of basic sample templates to cover the range of samples to be measured.
3. Selecting the detector, the collimator, and the template, and entering the parameters to describe the object.

### ***Detector Characterization***

This is done, using a few NIST-traceable sources and the well-known MCNP Monte Carlo modelling code. Specifically, the radiation response profile of each individual detector is determined for a 1000meter diameter sphere around the detector over a 45 keV through 7 MeV energy range. The results of this characterisation are delivered to the user in the ISOCS software. When multiple detectors are characterised, all are available for selection by the ISOCS user.

### ***Geometry Template Definition***

Currently, ISOCS has ten standard geometry templates plus an additional set of special surface contamination templates for D&D applications. If these very flexible standard templates aren’t adequate for your application, custom templates can be created.

### ***Parameter Entry***

This part is performed by simply making a few physical measurements of the sample and entering them into the appropriate ISOCS calibration template, the source-detector geometry is defined.

The user may also select from a list of pre-defined ISOCS Shield Collimators or enter his own shield’s parameters. Both circular and rectangular shields and collimators can be used.

This data is then automatically combined with the data from the detector characterization to generate an efficiency calibration curve. This calibration can then be stored and used in any other software

platforms [Genie-PC, Genie-2000, Genie-ESP], and re-used just as if it had been produced by the traditional “custom source” method.

An additional benefit to this mathematical approach to calibration is the ability to easily play “What if?” For example, a series of ISOCS calibrations can be performed, each with the same sample dimensions but different sample density parameters. By using each such calibration in turn to assay the spectrum from a single sample count you can easily determine the impact of various sample matrices on the results of the assay. This can be an invaluable tool when it’s needed to determine the assay error bounds for large, difficult to characterise samples such as boxes, drums, floors, and walls.

### ***Sample Types and Geometries***

At the present time ISOCS comes with ten standard geometry templates. Each of these template scan be modified by the presence or absence of either of the collimator configurations included with the ISOCS shield assembly. Additional templates will be added as they are developed and, for applications with special requirements, custom templates can be provided. The standard ISOCS geometries and typical applications for each are:

#### ***Simple Box***

A basic rectangular carton or waste shipping container or a truck filled with scrap iron, or even a small building.

#### ***Complex Box***

The same as the Simple Box, but with a more complex sample matrix. It includes the ability to distribute the contamination across as many as four layers of material and/or to place an additional concentrated source anywhere in the container. Ideal or use in “What If?” analyses of non-uniform distribution in waste assay containers.

#### ***Simple Cylinder***

A basic barrel, tank, or drum. In an emergency, it could also be used for a quick whole body contamination count.

#### ***Complex Cylinder***

The same as the Simple Cylinder, but with a more complex sample matrix. It includes the ability to distribute the contamination across as many as four layers of material and to place an additional concentrated source any wherein the container. Ideal for use in “What If?” analyses of non-uniformity in barrel sand drums.

#### ***Pipe***

A pipe, empty or full, including material that has plated out or built up on the inner walls.

#### ***Circular Plane***

The end of a barrel or tank, the bottom of a bottle containing a sample, or a filter cartridge. This would also be used for in situ measurements of ground. The radioactivity can be distributed in any manner in up to ten layers of sources/absorbers.

#### ***Rectangular Plane***

A floor, wall, or ceiling, or soil in situ. The template allows for surface contamination as well as up to ten layers of internal contamination behind an absorber such as paint, panelling, or a floor covering.

*Well or Marinelli Beaker*

Used for well logging applications, or for standard Marinelli beakers.

*Sphere*

Internally contaminated spherical objects, like large pipe valves.

*Exponential Circular Plane*

For soils or neutron-activated concrete or other objects where the distribution of radioactivity can be described by a exponentially increasing then decreasing function.

Special templates additionally available:

- Surface contamination on I or H beam.
- Surface contamination on round tube/pipe/tank, inside or outside.
- Surface contamination on square tube/box inside or outside.
- Surface contamination on angle or L beam.
- Surface contamination on inside of room/box with detector in room.
- Volumetric contamination in partially filled horizontal pipe/tank.
- Volumetric contamination in partially filled conical tank.



## 5 - STATE OF THE ART IN DIFFERENT COUNTRIES

This chapter gives a practical demonstration of the release measurement studies described in the previous chapters. The first part contains reviews of the national regulations, norms and standards applied by Sweden, France, Germany, Italy, Spain, United Kingdom and Belgium, as reported at the end of year 2000.

It is also to be noted that the regulation and practices described below are relevant only for radioactive material, arising in the nuclear fuel cycle industries.

Technical characteristics, principles and performances of instruments presently used for free-release measurements are given in the second part.

### 5.1 - National Regulation and practice

This chapter should be read in parallel with the first part of the chapter 2: 'Regulatory aspects' allowing comparison to be made between the international recommendations and standards and the practices applied in different countries.

#### 5.1.1 – Sweden

*In the nuclear field:*

The national regulator, The Swedish National Institute for Radiation Protection, has issued (1996) a regulation concerning the free release of material from nuclear installations, including restricted release of used oil and the restricted release as waste for Municipal waste handling.

The free release criteria are:

- 40 kBq/m<sup>2</sup> of beta and gamma;
- 4 kBq/m<sup>2</sup> of alpha,

averaged over 300 cm<sup>2</sup>.

If it is obvious that alpha contamination levels are known to be very low or non-existing, then the level of alpha contamination does not have to be measured.

Additionally the specific activity (mainly when large volumes are taken out from controlled areas) for free release should not exceed 500 Bq/kg including a maximum of 100 Bq/kg for alpha emitters with long half-life. When waste is sent to Municipal Waste handling, the specific activity must not exceed 5 000 Bq/kg beta + gamma and 500 Bq/kg alpha. No weight value for averaging is given in the regulation. Instead it is decreed that the measurement procedures shall be known by the authorities.

The measurement procedures at the nuclear installation should be arranged according to an instruction approved at the site. The national regulator as a part of a general plan for reviewing the radiation protection management at the site will review these procedures.

The usual practice is to make measurements on accessible surfaces of the material for release with gas-filled proportional detectors with a surface area of 100-200 cm<sup>2</sup>. The procedures put a great responsibility on the Health Physics engineers performing the measurement or instructing the technicians who perform the measurement. The procedures allow the Health Physic engineer to consider where the material comes from and the contamination types in that area when deciding on the measurement method. If the contamination is difficult to find due to for example a high background, a complicated geometry, hard to measure radionuclides, or if the object is large then additional measurements are performed including smear tests and/or gamma spectrometry depending on the circumstances. If large amounts are released then specific actions are taken to estimate the maximum contamination level as well as the total contamination. Large quantities are released only after the authority has accepted the measurement procedure and the results, this is done on a case by case base.

Smear test samples are measured inside a shielded proportional counter for time periods guaranteeing detection levels below the regulated release levels. The proportional counter measures beta (+ gamma) and alpha separately. Gamma spectrometry is performed with collimated, high purity Germanium detectors, at fixed distances from the object to be measured. Depending on the type of object to be measured, several pre-calibrated geometries (including prescribed measurement times) are available. When the geometry deviates too much from those which are pre-calibrated the persons who perform the measurements use computer based calculations to calculate new calibration factors.

*The non-nuclear field:*

The national regulator has also issued release criteria for waste from non-nuclear installations (mainly medical applications). The criteria states that at the most, solid waste can include 1 ALI per package and that the dose rate on the outer surface should be below 5 µGy/h. The highest allowable activity for release of sealed sources for waste handling is 50 kBq.

### **5.1.2 Spain**

In Spain no national policy is established for free release of solid materials only for liquid and gaseous effluents from nuclear power plants. The Nuclear Safety Council defines specific values in the operating authorisations. The general values used in Spain are the following:

- Surface contamination limits: 0.4 Bq/cm<sup>2</sup> for β-emitters and 0.04 Bq/cm<sup>2</sup> for α-emitters.
- Mass specific activity limits: national regulatory body recommends 0.2 Bq/g for β-γ emitters and 0.04 Bq/g for α-emitters.
- Values from IAEA (unconditional release and concrete disposal) and EU (metallic scraps) studies have been proposed for decommissioning of Vandellos nuclear power plant. ENRESA and Spanish nuclear facilities have submitted several specific studies to obtain a case by case authorisation.

### 5.1.3 *Belgium*

**SCK•CEN** - Belgium:

There are no legal values concerning the free-release of material, except for liquid waste (effluent) and radioactive gas effluent (aerial emission). On a case by case basis, the health physics in SCK•CEN lay down the free-release level recommended by IAEA and EC to perform unconditional release of materials. QA dossiers consisting of the historic data, together with detailed characterisation of the material, are established. The independent radiation protection control organisation and/or the competent authority are informed and thus given the opportunity to verify compliance with the release criteria.

### 5.1.4 *France*

In France, the practice of any unconditional clearance levels for very low level radioactive waste is excluded. This has been decided by the Nuclear Safety Authority (DSIN), so as to avoid any loss in the waste producer responsibility.

Before any dismantling task, the owner of the facility has to provide a detailed waste management plan, which has to be approved by the Nuclear Safety Authority. For each kind of waste, this management plan, called the “Waste study”, has to precisely describe all the steps involved in its management: Any very low level waste disposal, treatment or recycling must be authorized by the Safety Authority after an assessment.

Since this policy has been defined, no large scale release of low level waste can be given as example.

Low level waste, with specific activities below  $1 \text{ Bq}\cdot\text{g}^{-1}$  ( $\alpha$ ) or a few tens  $\text{Bq}\cdot\text{g}^{-1}$  ( $\beta, \gamma$ ) will be disposed in a specific plant. Acceptance criteria are currently being completed.

### 5.1.5 *Italy*

Before verifying if the material or the component has a residual contamination higher or lower than the reference limits, it is required to collect some information and to fix some criteria, e.g. how to consider the materials with inaccessible surfaces or requiring unjustified costs to make them accessible. The European Community Commission recommends to take into consideration those materials as radioactive and to consider the type of plant, its operation history (accidental releases, leakage, etc.) and its particular radioisotope composition. Isotope composition analysis including the difficult detectable nuclides and determination of relationship of such nuclides with  $^{60}\text{Co}$  and  $^{137}\text{Cs}$ , which are easier to measure, is necessary

### 5.1.6 *Germany*

The German waste management strategy is governed by two options:

- Clearance of the material (after decontamination and release measurement). After clearance, the material is no longer regarded as radioactive in a legal sense.
- Final disposal of the material as radioactive waste in a deep geological repository

In Germany, clearance of material originating from the operational or decommissioning phase of nuclear installations as well as from other authorised use of radioactive material is regulated in the

Radiation Protection Ordinance (RPO) of July 2001 which is based on the German Atomic Energy Act. The RPO transforms the EURATOM Basic Safety Standards (BSS) into national legislation.

The clearance regulations in the new RPO are characterised as follows: One set of clearance levels (CL) exists for each of the clearance options which are described in the following. Each set contains CL for about 300 nuclides (those for which exemption levels exist in the BSS). All sets of CL are derived on the basis of 10  $\mu\text{Sv/a}$  individual dose.

The following clearance options are contained in the German RPO:

- Unconditional clearance
  1. of all solid materials for reuse, recycling or disposal including building rubble of less than 1 000 Mg per year.
  2. of building rubble and soil of more than 1 000 Mg per year.
  3. of buildings for reuse or demolition.
  4. of nuclear sites (after removal of the buildings).
- Clearance
  1. of solid materials for disposal on landfills or for incineration.
  2. of buildings for demolition only.
  3. of metals for melting only.

The clearance options listed under the first category are termed “unconditional clearance” because no restrictions concerning the destiny of the material exist after clearance (i.e. the material need not be traced to a final destination). The clearance options listed under the second category “clearance” could be called “conditional clearance” because certain conditions must be fulfilled before clearance can be achieved. However, it is more appropriate to speak of “clearance of material for a certain purpose”.

The clearance regulations in Germany have a complex structure. They are, however, one of the most advanced and comprehensive worldwide. Their applicability has been successfully demonstrated in various licensing procedures, especially in decommissioning projects of nuclear power plants, research reactors and fuel cycle installations.

The basis for the derivation of all sets of clearance levels has been compiled in the German Radiation Ordinance “Verordnung über den Schutz vor Schäden durch ionisierende Strahlen” (Strahlenschutzverordnung StrlSchV), 20<sup>th</sup> July 2001, Federal Gazette Part I, G 5702 No. 38, 2001, p. 1714 and shall not be repeated here. The following table contains some examples of clearance levels for a few relevant radionuclides.



Examples of clearance levels for a few relevant radionuclides (German Radiation Protection Ordinance)

Clearance option	<sup>3</sup> H	<sup>14</sup> C	<sup>55</sup> Fe	<sup>60</sup> Co	<sup>137</sup> Cs	<sup>131</sup> I	<sup>234</sup> U	<sup>242</sup> Pu	<sup>241</sup> Am	unit
I.1 unconditional	1 000	80	200	0.1	0.5	2	0.4	0.04	0.05	Bq/g
I.2 building rubble	60	10	200	0,09	0.4	0.6	0.4	0.04	0.05	Bq/g
I.3 buildings, reuse	1 000	1,000	1 000	0.4	2	10	1	0.1	0.1	Bq/c m <sup>2</sup>
I.4 nuclear sites	0.04	6	0.03	0.06		0.2	-	0.04	0.06	Bq/g
II.1 disposal	1 000	2000	10 000	4	10	20	9	1	1	Bq/g
II.2 buildings for demolition	4 000	6,000	20 000	3	10	600	10	2	3	Bq/c m <sup>2</sup>
II.3 metal scrap for recycling	1 000	80	10 000	0.6	0.6	2	2	0.3	0.3	Bq/g

Experience with release of materials from controlled areas and sites exists in Germany from a number of NPP decommissioning projects containing smaller NPPs like

- VAK Kahl (BWR, 16 MWe, operation 1961-1985) ;
- KRB-A Gundremmingen (BWR, 250 MWe, operation 1966-1977) ;
- HDR Karlstein (Superheated BWR, 25 MWe, operation 1969–1971);
- KKN Niederaichbach (GCHWR, 100 MWe, operation 1972-1974, completely dismantled) as well as larger NPPs like;
- KGR Greifswald (5 block VVER, 440 MWe each, operation 1973/89-1990);
- KWW Würgassen, (BWR, 670 MWe, operation 1971-1995).

The total waste masses differ according to reactor size and reactor type. However, one common feature can be found amongst all of these decommissioning projects: the radioactive waste which has to be finally disposed of (in a deep geological repository) amounts to only a few percent (typically 3 to 5%) of the entire mass of the controlled area. The rest of the material is decontaminated (if necessary) and cleared.

It has been found that the German clearance levels can be measured for each clearance option. A number of measurement techniques have been developed for this purpose over the last decades. The most important measurement device is the so-called release measurement facility (RMF, see Figure 5.1.6.1) where the material (typically up to a few 100 kg or even 1 Mg) is surrounded in the measurement chamber by large area detectors (usually 24) on all 6 sides. The gamma measurement is fast and accurate allowing a daily throughput of up to 10 Mg. Calibration racks are depicted in Fig. 5.6.1.2

Figure 1: **Release measurement facility**



Figure 2: **Calibration racks for release measurements facilities**



A number of other measurement techniques for surface and mass specific activity exist. Comparatively new developments are the in-situ-gamma spectrometry (for building surfaces and sites, see Figure 5.2.4) and the cobalt coincidence monitor which is especially sensitive to  $^{60}\text{Co}$ , the key nuclides in most NPPs. Correlation of nuclides which are hard to measure with easy-to-measure nuclides is also a common approach.

### 5.1.7. *United Kingdom*

The definitive document defining the use and control of radioactive material in the UK is the 1985 Ionising Radiation's regulations (IRR85).

#### *Surface Contamination Limits*

Regulatory responsibility for release of material of a radioactive nature is held by the HMIP and MAFF (Her Majesty's Inspectorate of Pollution and the Ministry of Agriculture, Fisheries and Food) which have now been combined into the EA (Environmental Agency). The methodology used to grant permission for the release of material is on an ad hoc basis.

#### *Current UK practice*

The current practice on UK nuclear sites is based on the historically defined surface clearance derived Working Limits (DWLs), which were originally set up in the 1950s and which were included as a condition of Nuclear Site Licences granted by the Nuclear Installation Inspectorate – (NII). The limits were as follows:

#### *Surface Contamination Limits*

- 0.4 Bq/cm<sup>2</sup> Alpha emitters excluding uranium.
- 4.0 Bq/cm<sup>2</sup> general beta plus low toxicity alpha.
- 40 Bq/cm<sup>2</sup> Low toxicity beta.

These represent:

- Total activity fixed and loose.
- Activity averaged over 300 cm<sup>2</sup> for inanimate objects.
- Activity averaged over 1 000 cm<sup>2</sup> for walls and floors.

The IRRs introduced in 1986 gave generally more relaxed levels of surface contamination. Schedule 2 of IRR includes a full list of all likely nuclides. IRR85 defined the release level at one third of the quantities defined in Schedule 2. However, under ALARA (As Low As Reasonably Achievable), sites chose to apply limits in operation prior to IRR85 as they could be practicably applied. It should be noted that IRR85 indicates that there are some nuclides over which *more restrictive* control should be applied. It is suggested a Radiation Protection Advisor (RPA) should be consulted when these nuclides are present in significant quantities.

If <sup>231</sup>Pa, <sup>236/7</sup>Np, <sup>228</sup>Ra, <sup>254</sup>Cf, <sup>227</sup>Ac, <sup>210</sup>Pb are present or suspected, the RPA should be consulted. A more exhaustive list is given in Schedule 2 of IRR85.

The 1993 Radioactive Substances Act RSA93 (Substances of Low Activity Exemption Order 1002 1986) gives free release limits for volume measurements: For distributed bulk activity this is: 0.4 Bq/g of added activity.

## 5.2 Practical experiences of devices used as release measurement methods

### 5.2.1 France *“Bench for low level Control for beta-gamma emitters” Plastic scintillators for Gross gamma counting*

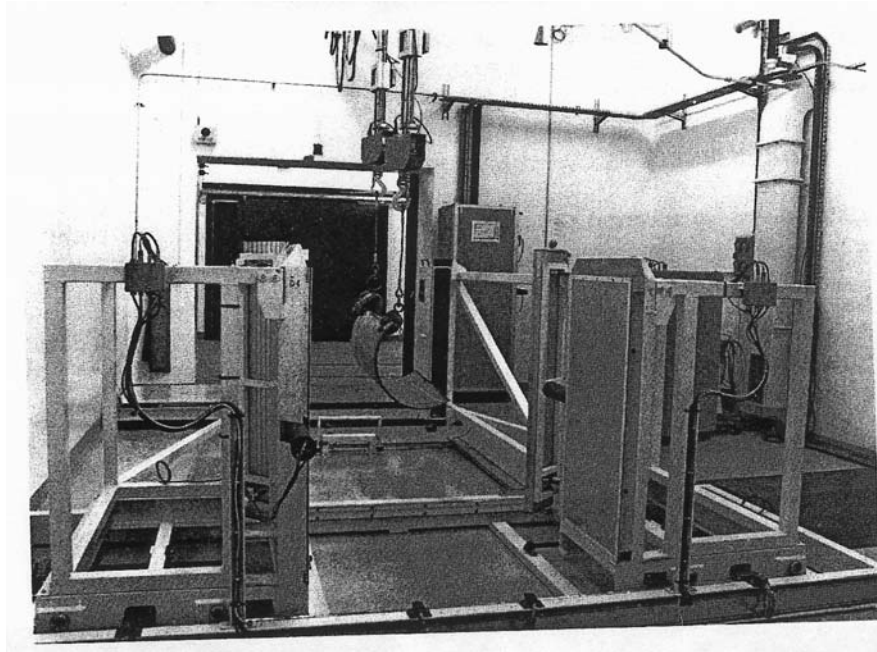

This device was developed to measure the activity of metallic waste coming from the cooling circuit of the reactors G2-G3 of Marcoule, mainly contaminated with  $^{60}\text{Co}$  and  $^{137}\text{Cs}$ .

It is semi-automatic (the counting parameters can be set according to the geometry of the elements to control). It allows the control of elements with the following characteristics:

Maximum dimension: 2 m long, 1 m large and 1 m high  
Weight: from 20 to 500 kg  
Radionuclides measured: beta-gamma emitters

**Technical characteristics:** The counting bench consists of two units:

- A *mechanical unit* for the gripping and the transfer of the elements (dimension: 7m long, 0,5 m wide and a variable high)
- An *automatic unit* which controls the measurement and the treatment of the results. This unit is made of:
  - detectors (two plastic scintillators with a dimension of  $1000 \times 500 \times 55$  mm and a weight of 32 kg);
  - a command post (electronic CEA, control command and synoptic associated, PC, recorder and printer).

**Radioelements measured:** beta - gamma emitters.

**Principle:** After being weighted, the element passes between the two plastic scintillators. The distance between the detectors and the element to control is set with the help of an optic system. The automatic unit takes into account the measurement parameters for the selection of the element according to the specific activity limit.

**Performance:** 6 elements per hour,  
 detection efficiency > 2% for  $^{60}\text{Co}$  in the worse geometrical case  
 detection limit: < 2 000 Bq for 120 s counting.  
 110 tons of steel with low level contamination had already been controlled. After control, all of them had been recycled as nuclear waste containers.

### 5.2.2 Spain

#### *“Spanish scintillation device for soil measurements” NaI scintillator for surface measurements*



This device has been developed to measure the activity of soils before free-release in the decommissioning of an old uranium mill. It is a portable automatic instrument using scintillation detectors. The electronic system permits gamma global measurement or specific isotope determination with appropriate channel windows.

**Technical characteristics:** Detector: mainly two 2"x2" NaI(Tl) detectors one placed near the soil and the other one at 1 meter. It can be used with plastic scintillators to measure surface contamination on equipment's or floor or walls, and with one NaI(Tl) to do measurements inside boreholes.

Measuring unit: base in microcontroller Motorola MC-68705-03 permits acquisition and storage of data and their transmission through serial port (RS-232) to personal computer. It is also provided with a high

voltage supply, an amplifier and other electronic components. The device is completed with a visual unit, displaying measurement results and a keyboard to control measuring parameters and identifications. Dimensions and weight: 7 kg and maximum dimensions 26x31x15 cm.

**Radionuclides measured:** gamma emitters (a practice occurred for measurement of  $^{226}\text{Ra}$ ).

**Principle:** the operator walks following determinate lines and the device acquires radiological data and counts steps to define the distance run.

**Performance:** counting time is preselected through measuring unit. The operator can do between 10 and 20 km/day.

### 5.2.3 *Belgium* “Portable ratemeters for surface measurements” *Belgoprocess*

At Belgoprocess (including the former reprocessing plant Eurochemic) in-situ measurements of alpha and beta-gamma emitters for unconditional release of materials (metal, concrete, etc.) are carried out with portable ratemeters types PCM 5/1A, Delta 3 and Electra. These ratemeters are mainly used with scintillation probes type DP2/4A (sensitive area 50 cm<sup>2</sup>), DP2R/4A (sensitive area 50 cm<sup>2</sup>) or DP6A (sensitive area 100 cm<sup>2</sup>).



#### **Technical characteristics:**

The portable ratemeter consists of two circuit boards: HV/Amplifier and Processor and Interface board, housed in a painted rectangular section aluminum extrusion. A LCD display (display of measured rate is in both analogue and digital format) is positioned upon the digital board and is visible through a screen on the top panel of the extrusion. Operation of the unit and entry of set-up parameters can be performed via a membrane keypad on the top panel. Audible indication of measured rate is given by an internal sounder and an external socket is provided at the handle end to enable the audible output to be transferred to headphones. Probes can be connected to the unit. The used dual probes, type DP2/4A and DP2R/4A, are hand held scintillation detectors with a 49 cm<sup>2</sup> sensitive area (100 cm<sup>2</sup> for DP6A), used for monitoring alpha and beta contamination. Each probe has

a painted aluminum housing, with a light-tight aluminized polycarbonate window protected by a chrome plated grid. The scintillation phosphor, mounted behind the window, has a layer of silver activated zinc sulphide on a thin sheet of plastic scintillator. A photomultiplier tube and a thick film resistor network are mounted in the handle of the housing.

**Radionuclides measured:** alpha and beta-gamma emitters.

**Principle:**

The surface contamination monitoring for unconditional release of materials and structures from decommissioning consist of two successive measurements on the entire (100%) surface of the submitted material (metal, concrete e.g.). Measurements are performed independently by two radiation protection officers. As long as the material is on-site, an independent radiation protection control organization has the opportunity to make supplementary checks. For materials that have been decontaminated, a delay period of three months is foreseen between the two measurements.

**Performance:**

As alpha particles have a small range in air, and as this range is effectively reduced by the detector window, the probe should be placed as near to the surface to be measured as possible, and at a distance not more than 2 cm. Beta particles have a greater range in air, but to maintain maximum efficiency, the probe should still be placed as near to the surface to be measured as possible. When using the probe to detect very low levels of alpha contamination, or low levels of beta contamination over large areas, the probe should be moved extremely slowly over these areas. Each area should be «seen» by the probe for at least a few seconds.

**5.2.4 Germany**                      ***“Collimated In-situ gamma Spectrometry”***  
***High purity Germanium***

Figure 5.2.4: Release measurements for sites and buildings



**Technical characteristics:** This equipment was developed to check mass- or surface- specific activities on outdoor grounds and inside the buildings in controlled areas. The device is a collimated high-purity germanium detector which measure directly in the regions of interest (“in-situ”).

- The **detector** is a 41% p-type HPGe-detector which allows measurements of nuclides with low photon energies. A nitrogen tank is used as cooled system.
- An optimised **collimator** made out of brass and low natural activity lead-bismuth-tin-alloy surrounds the detector. The detector is shielded for radiation from the rear hemisphere. The wall thickness must guarantee sufficient lateral shielding even in the presence of high-energy radiation (e.g.  $^{60}\text{Co}$ ).
- Concerning the **electronic** equipment and **Software**: a programme for automatic measuring sequences and for quality assurance is used (Genie PC/OS/2) in addition to conventional visualisation and analyses software. The electronic equipment weighs less than 6 kg and can be run in the battery mode for two to three hours.
- The detector can also be operated without collimators for integral measurements in defined geometries

**Radionuclides measured:** gamma emitters.

**Performance:** The detection limit of a measuring device serves the assessment if this device is suitable for the required purpose. Some practical examples for minimal detectable activities are:

- Under rigid conditions (maximum collimation, some migration of the nuclides in concrete) and normal dose rates due to natural nuclides detection limits of 800 Bq/m<sup>2</sup> for  $^{60}\text{Co}$  and 1 400 Bq/m<sup>2</sup> for  $^{137}\text{Cs}$  in three minutes are reached. A contamination with a nuclide vector containing only 20-30% of these nuclides can be detected according to the requirements of German radiation protection ordinance.
- For the relatively difficult to measure activity of  $^{238}\text{U}$  (via  $^{234\text{m}}\text{Pa}$ ) a detection limit of 150 Bq/kg is reached after 15 minutes. Uranium can be measured on storage pits with any enrichment. The observance of exemption values for deposition of waste contaminated with the more difficult to measure nuclides of the nuclear fuel cycle can be proved.
- In the same measurement time a surface contamination of 500 Bq/m<sup>2</sup>  $^{235}\text{U}$  is detectable and can be discriminated from the natural  $^{226}\text{Ra}$  and  $^{235}\text{U}$  186 keV background in concrete containing 1 Bq/kg  $^{235}\text{U}$ .

Depending on the collimator used and the height of the detector above the surface, this spectrometer averages over an area between 0.4 and more than 10 m<sup>2</sup> in one measurement. The software provides for measurement cycles of up to 250 measurements per day.



## 5.2.5 Sweden

*Collimated in-situ gamma spectrometry for Release Measurements*

Two different equipment's (stationary and mobile) are used for free-release measurements at Ringhals nuclear power plant.

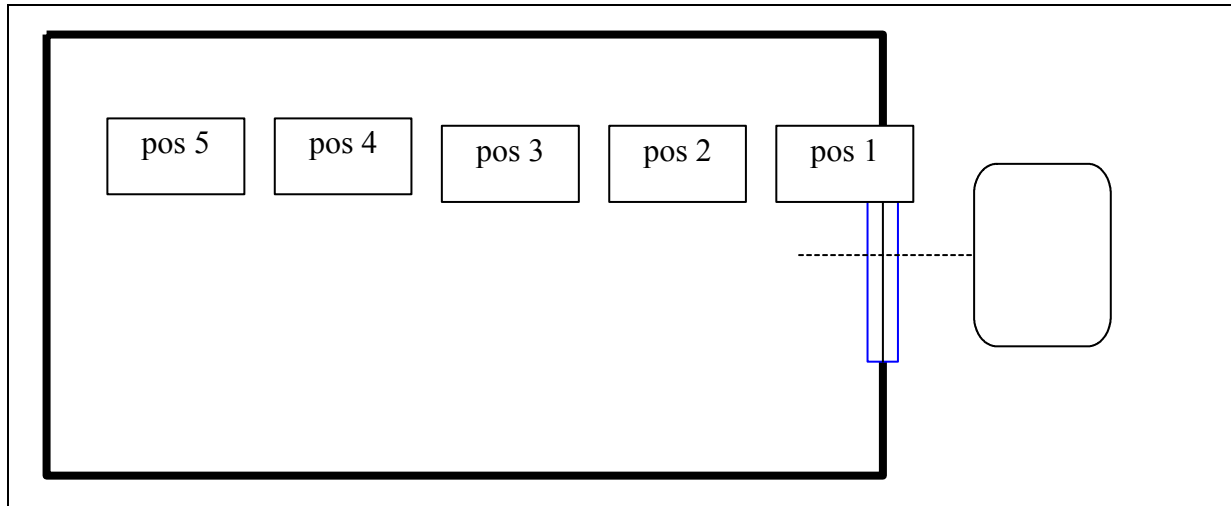
**Technical characteristics:**

The stationary equipment is used to measure the mass specific activities in small objects (maximum size of an object is  $2 \times 2 \times 1,5 \text{ m}^3$ ). The detector is a 10% Ge-detector. A nitrogen dewar is used as cooling system. Measurements can be done at 5 different distances, see figure (from 2.46 m to 8.46 m). An optimized shielding made out of lead surrounds the detector. For measurement four different collimators can be used. (For free-) release measurement a fully open collimator is used.)

The mobile equipment is used to measure the mass specific activities in large containers (maximum size of an object is  $6 \times 2.5 \times 2.5 \text{ m}^3$ ). The detector is a 17% Ge-detector. A nitrogen dewar is used as cooling system. The distance between the detector and the front of the container is 7 m. The detector is placed in an optimized shielding box.

Concerning the electronic equipment and software associated to those two systems: a programme for automatic measuring sequences and for quality assurance is used (PROcount, for the stationary equipment and Genie-PC for the mobile one) in addition to conventional visualization and analysis software.

**Radionuclides measured:** gamma emitters.

**Performance:**

Free-release measurements are made during 12-24 hours. The minimum detectable activity is below 100 Bq/kg for  $^{60}\text{Co}$  and  $^{137}\text{Cs}$ .

### 5.2.6 *United Kingdom Groundhog Site Survey Methods* *AEA Technology*

The aim of the GROUNDHOG™ system is collecting and managing information from surveys of contaminated land. Traditional techniques for the assessment of residual radioactivity in contaminated land, notably brown-field sites, may not yield the speed and accuracy now required for estimates of risk and remediation cost. Detailed site investigation is often limited by the time and the cost of laboratory-based analysis technical issues, so that the mapping of priority areas of a site, can be unnecessarily delayed and expensive. The system allows large volumes of data to be gathered autonomously, allowing the survey operators to concentrate on observing and recording site conditions rather than recording instrumental data. It has been used to survey a large number of sites in the UK and provide the measurement information for release operations.

#### **Technical characteristics:**

Along with sensitive radiotope measurement to release levels, the measurement information produced includes high accuracy measurement of the position of every sample taken by the use of a GPS location and recording system. The data gathered during surveys is managed electronically, from the point of measurement through to the final customer report. For large or complex surveys, data can be easily processed on-site and thus survey and/or remediation strategies adjusted without delay. The use of modern data visualization software allows survey results to be routinely displayed in a way easily understood and for the service to be readily customized for large project requirements.

#### **Principle:**

A highly efficient 3"x3" NaI Detector is used with multielement window data recording to provide sensitive measurements of key radionuclides from both natural background and site contaminants. The toughened and waterproofed detector is automatically gain stabilized and robustly connected to a portable instrumentation package for electronics support, signal processing and data recording which includes the GPS position marking capability. The package is mounted conveniently in a dedicated backpack. For detailed surveys, readings are typically taken every metre on a site, and sophisticated post-measurement data analysis techniques convert this to radiation level maps and other convenient output forms.

#### **Performance:**

The instrument can detect subtle changes in the background radiation – even detecting the different natural radiological content of the aggregates used in concrete. This allows very low level contamination trends to be identified and sites to be rapidly surveyed at release levels. The system is currently being deployed for the assessment of sites contaminated with isotopes used historically in various industries and “technologically enhanced” naturally-occurring radioactive materials such as fly-ash and foundry slag. Groundhog is also being used to support remediation strategies based on *in situ* selective sentencing of waste, which minimize the waste volume removed from a site.

### 5.2.7 U.S.A *In situ gamma spectrometry methods*

In situ Gamma-ray spectroscopy is often used to measure suspect waste and confirm that release criteria are met. One of the most common applications is in the measurement of radionuclides on or near the surface of soils. This is performed by placing the collimated Ge detector in a standard position (commonly one metre) above the soil, the count is made and because of the large sample size, detection sensitivity is close to that in laboratory measurements.

#### ***Example - FUSRAP Environmental Remediation Site:***

The US Army Corps of engineers are working on the FUSRAP Environmental Remediation Site, using the above (ISOCS) technique for soils, plus underground Ge gamma-ray spectroscopy and Ge gamma spectroscopy soil sorting, with the objective of confirming the bulk of the site materials for release from regulatory control.

#### ***Example – Kerr-McGee Site in West Chicago***

##### **Technical characteristics:**

As part of the ongoing remediation activities at the Kerr-McGee (K-M) site in West Chicago, Illinois, large volumes of contaminated soil must be excavated and replaced with acceptable backfill material. To satisfy this need for backfill material and to reduce off-site disposal costs, K-M has developed a method for processing the excavated soil.

On-site processing operations separate the original input material into three output streams, each with a different range of particle sizes. During this process, most of the radioactive contamination is retained in the material with the smaller particle sizes, which is shipped off-site via rail car for disposal. The output stream with the largest particle sizes is continuously monitored with a customized gamma spectroscopy system to quantify residual activity levels.

Measured  $^{232}\text{Th}$ ,  $^{238}\text{U}$  and  $^{226}\text{Ra}$  activity results are used to divert the monitored material into two final output streams. Material with results exceeding the applicable release limits is reprocessed for further activity reduction. Material meeting the release criteria is stored for use as backfill in excavated areas.

##### ***Initial Processing***

Excavated soil is taken from a stockpile and loaded into the primary feed hopper at an average rate of approximately 100 tons/hour. The soil is moved on conveyor belts through a series of water sprayers, tumblers and screens, to segregate material with the largest particle sizes. This material is deposited onto a special Activity Characterisation Conveyor (ACC) belt for analysis.

##### ***Measurement Method*** (see principle)

##### ***Final processing***

Measurement results are used to control a diverter gate, which divides all monitored material leaving the ACC into one of two final output streams.

The proper diverter gate position is re-determined after each 30-second acquisition/analysis cycle, with a time delay to allow the “sample” of material corresponding to each cycle to reach the gate.

Material with long-term average activity results exceeding the release limits is diverted to a “recycle pile” inside the controlled area, then saved for subsequent reprocessing.

Material satisfying all release limits is routed to a final conveyor chute and deposited outside the controlled area. The exit point of this conveyor can be moved to allow accumulation of multiple “backfill piles”, pending transport of this material to previously excavated areas on K-M property.

After placement and compaction of backfill material in remediated areas, *in situ* gamma spectroscopy measurements are performed at selected survey locations for final verification purposes. The system used for these *in situ* measurements includes a portable MCA, laptop PC and collimated HPGe detector mounted on a trailer. A utility vehicle is used to pull the trailer and provide 12V battery power for all equipment.

Results from these final *in situ* measurements have been consistent with the original results from continuous monitoring of processed material on the ACC belt. Additional comparative measurements based on traditional laboratory sample analyses have confirmed that the original results used to release the backfill material are accurate and reliable.

**Radionuclides measured:** gamma emitters.

**Principle (Measurement method)**

A customized gamma spectroscopy system is used for continuous monitoring of material on the ACC belt. This system includes two collimated HPGe detectors mounted directly above the ACC, inside a climate-controlled enclosure.

The system is controlled by a DEC AXP computer and a special software package developed by Canberra Industries. This system also includes a separate PC and monitor for graphical displays of material output vs time, a printer and a backup tape drive.

Material is transported beneath the detectors at speeds ranging from 3-12 feet/minutes. To compensate for varying feed rates, height sensors automatically adjust the ACC belt speed to maintain a constant 8” height of material on the belt.

The effective sample size viewed by the detectors is an 8” thick rectangular slab, approximately 10 cubic feet in volume. Side rails above the ACC belt maintain a constant 44” width of material, providing a fixed counting geometry and allowing a single efficiency calibration function to be used for all analyses.

A complete acquisition and analysis cycle is repeated at 30-second intervals, which is adequate to achieve the required MDA values for <sup>232</sup>Th, <sup>238</sup>U and <sup>226</sup>Ra detection. Spectra from consecutive counts are summed on a channel by channel basis, then reanalyzed to determine “long-term average” activity values. Updated long-term average values are recalculated following each 30-second cycle, after summing all spectra acquired in the last 20-minute time period.

Long-term average activity results are compared to material release limits established for the K-M site. These release limits are as follows:

Total Radium - 7.2 pCi/g (5.0 + 2.2 Bq/kg)  
[<sup>226</sup>Ra + <sup>228</sup>Ra]

Total Uranium - 10 pCi/g plus credit factor (credit factor = 2 to 8 pCi/g,  
 [2.046 x <sup>238</sup>U] maximum of 8 allowed if Total Radium <5.0 pCi/g)

**Performance:**

For the measurement of radionuclides on or near the surface of soils:

This is performed by placing the collimated Ge detector in a standard position (commonly one metre) above the soil, the count is made and because of the large sample size, detection sensitivity is close to that in laboratory measurements. Typical results are shown in the table below, (for a 15 minute count on New England soil, 40% Ge detector 1m above the soil , and with uniform distribution of radioactivity in the soil).

Nuclide	LLD (PCi/g)	LLD (Bq/kg)
<sup>60</sup> Co	0.02	0.8
<sup>137</sup> Cs	0.03	1.1
<sup>152</sup> Eu	0.1	0.35
<sup>238</sup> U [ <sup>234</sup> Th]	3	95
<sup>238</sup> U [ <sup>234m</sup> Pa]	2.8	110
<sup>235</sup> U	0.3	10
<sup>241</sup> Am	1	3.6

**CONCLUSION:**

Processing of contaminated soil was performed at the K-M site from April to December in 1998, and resumed in early 1999. In the 1988 work, typical output of releasable backfill material during normal operating conditions was approximately 400 tons/day (about 50% of the original soil input). Final verification surveys using *in situ* measurement techniques have confirmed that this backfill material satisfies the applicable release limits. Approximately 43 000 tons (34 000 cubic yards) of backfill material was released in 1998, resulting in a significant cost savings compared to off-site disposal of all excavated material.



## 6 CASES STUDIES

### 6.1 Belgoprocess experience in Belgium (unconditional release of materials and structures from decommissioning).

In the framework of its activities in the decommissioning of nuclear installations, Belgoprocess applies the clearance practice in optimizing the volume of radioactive wastes. The first steps towards the practical application of the unconditional release of materials and structures were difficult, however, as it was required to convince the authorities of the application of the unconditional release practice as such. The absence of any Belgian (nuclear) regulation for unlimited reuse or unconditional removal of suspected and/or decontaminated materials to a municipal or industrial disposal ground for inert wastes, in combination to the absence of internationally accepted unconditional release limits at that time, resulted in a policy of minimization instead of optimization.

The first practical experiences were acquired in the period 1988 to 1991. Two small buildings 6A/6B of the former Eurochemic reprocessing plant were decommissioned as a first large scale application of decommissioning and clearance in Belgium. The buildings were used to store end products of the reprocessing activities, i.e. uranyl nitrate and plutonium dioxide, as well as spent solvents. The decommissioning was set up in order to demonstrate the feasibility of the decommissioning of nuclear installations. Special attention was put on decontamination and clearance.

The two buildings comprised a total volume of 3 300 m<sup>3</sup> with 5 000 m<sup>2</sup> concrete surfaces, 47 tons of metal components and 950 m<sup>3</sup> of concrete. The average surface contamination was of the order of a few Bq/cm<sup>2</sup>, with spots up to 100 Bq/cm<sup>2</sup> for both alpha and beta emitters. Dose rates varied between 300 and 500 µSv/h.

All process equipment was removed and floors, walls and ceilings were decontaminated to background levels. Decontamination of metals was carried out using chemical methods, cutting and grinding, whereas concrete was decontaminated using scabbling and pneumatic hammering. Storage vessels, showing rather high alpha and beta contamination, were decontaminated to unconditional release levels of 0.04 Bq/cm<sup>2</sup> for alpha and 0.4 Bq/cm<sup>2</sup> for beta emitters. De-restriction of materials from the controlled area was carried out by the in-house Health Physics Department, and was confirmed by an independent radiation protection control organization. The clearance procedure included:

- two successive measurements of the complete (100%) surface;
- random control measurements by an independent radiation protection control organization;
- taking core samples and qualitative and quantitative sample analysis;
- specific activity limit set at 1 Bq/g (beta gamma) for 1 000 kg with a maximum of 10 Bq/g;
- destructive analysis of core samples showing the highest radioactivity levels.

Measurements were performed independently by two radiation protection officers. Specially assigned measuring instruments were used. As long as the material was onsite, an independent radiation protection control organization had the opportunity to make supplementary checks.

Taking core samples was necessary in order to facilitate the approval for unconditional release of debris after the demolition of the buildings. Samples were taken at places where previously spots were found with the highest radioactivity levels. At these places, the probability for penetration of contamination was found to be most likely. All analyses showed that the specific activity was well below 1 Bq/g, and hence the material could potentially be released. Although the psychological barrier towards clearance appeared to be high, finally about 65% of all metals could be cleared, the remaining quantity mostly not having the geometry to allow for adequate measurement. In various operations, 76 tons of concrete debris was generated, of which 53% was not radioactive. At the final demolition of the two buildings, another 2 350 tons of concrete debris was removed to a public disposal ground for inert wastes. As such, on a step-by-step or case-by-case basis, Belgoprocess finally succeeded in the removal from the controlled area of storage vessels and debris from the demolition of the buildings involved.

The project started in 1988, and green field conditions were met in 1991. The major problem in applying the clearance principle consisted in convincing the authorities to accept the unconditional release practice. Operations therefore had to be carried out on a case-by-case basis. Due to the lack of existing target values for clearance, limits were minimized and certainly not optimized. Hence, surface activity limits were set at the detection levels of the existing measurement equipment. This was a major reason why the Health Physics Department contributed for about 16 % to the overall decommissioning costs for the buildings 6A/6B.

On the whole, the project demonstrated, among others, the feasibility of decontaminating components and concrete structures up to very strict unconditional release levels. Since then, unconditional release or clearance can be considered as a routine practice, and a lot of effort is put in optimising related decommissioning and decontamination methods and techniques. On an annual basis several hundreds of tons of decontaminated materials are disposed of by application of the clearance principle.

From the beginning, as indicated, clearance at Belgoprocess is based on surface contamination monitoring. The method consists of two successive measurements of the entire (100%) surface of the submitted material. Measurements are performed independently by two radiation protection officers. Specially assigned measuring instruments are used. As long as the material is on-site, an independent radiation protection control organization has the opportunity to make supplementary checks. For materials that have been decontaminated, a delay period of three months is foreseen between the two measurements.

As decommissioning proceeded, however, a need existed to extend the available procedure to other types of measurements, and hence, to adapt the procedure to other geometrical material forms as well. A study of the types of materials present in the installations finally resulted in four types of clearance practices, i.e. surface contamination measurements, bulk type material measurements (e.g. active carbon in drums), measurement of materials stored in drums and materials that can be homogenized. For each type, a chronological sampling and measurement methodology was elaborated, independent of the unconditional release limits. Almost all types of clearance practices involve a combination of surface contamination measurements and specific activity measurements. As a result of many years of experience, it is the aim to reduce the second monitoring for surface contamination to about 10 % of the material to be screened. Indeed, the amounts of material that was found to be contaminated above the unconditional release levels during the second measurement, were only fractions of a percentage



of the total amount of material submitted. Moreover, in almost all these cases, the detected activity levels were only slightly above the limits.

In addition, a similar scenario was developed, considering also the non-nuclear aspects associated with the removal of materials from the site. In this scenario, reference is made to potential destinations of the material involved.

Important in the evaluation phase, and especially prior to decommissioning, are the historical data related to the installations and materials involved. All available information should be gathered and thoroughly studied, since it may reveal evidence on previous contamination and/or decontamination of installations or structures, on changes in equipment or modifications of structural components, and on types of decontamination techniques used (e.g. high pressure water cleaning or dry cleaning), and this throughout the lifetime of the installations.

The complete methodology has been discussed with the independent radiation protection control organization and with the authorities. So far, however, unconditional release practices are still based on a case-by-case approach, which implies that the authorities (and/or the independent radiation protection control organization) have to be consulted for each new type of material subjected to release. When releasing a certain type of material for the first time, the practice and used release levels have to be documented and to be justified considering the destination of the material. At present, unconditional release levels are used as mentioned in official IAEA, EC or OECD publications. Large discrepancies, however, can be found between these various publications.

### ***6.1.1 Unconditional release measurements of decontaminated concrete surfaces at the Eurochemic reprocessing plant***

In 1990, Belgoprocess started decommissioning of the main process building of the Eurochemic reprocessing plant at Dessel in Belgium on an industrial scale, following successful completion of its pilot project to decommission two small storage buildings for end products of reprocessing.

The reprocessing facility was constructed from 1960 to 1966, and from 1966 to 1974, a consortium of 13 OECD reprocessed 180 tones of natural and low-enriched and 30 tons of high-enriched uranium fuels in this demonstration plant. After shutdown, the plant was decontaminated to keep it in safe standby conditions at reasonable cost.

The main process building is a rectangular construction of about 80 m long, 27 m wide and 30 m high. The building has a total volume of 56 000 m<sup>3</sup>, it comprises 12 500 m<sup>3</sup> of concrete, 55 000 m<sup>2</sup> of concrete surfaces, and it contains some 1 500 t of metal and equipment structures. The core of the building comprises a large block of 40 main cells, containing the chemical process equipment. Access areas and service corridors are located on 7 floor levels. About 106 cell structures have to be dismantled. Some cells have contamination levels up to 125 Bq/cm<sup>2</sup> (beta) and 200 Bq/cm<sup>2</sup> (alpha). Some hot spots give gamma dose rates of several mSv/h.

Decommissioning involves the removal and decontamination of equipment from each cell, the decontamination of cell walls, ceilings and floors, the dismantling of the ventilation system, followed by a complete monitoring in view of unrestricted release of the remaining structures. Most of the work is done by hands-on operations under protective clothing tailored to each task. Some tool automation and automatic positioning systems are successfully applied.

Currently, decommissioning work has been carried out in 81 of the 106 individual cell structures to be dismantled. At the end of December 1998, 30 cells have been decontaminated to background levels. After completely dismantled, in 11 other cells concrete decontamination was started. In another 40 cell structures, component and material removal has been started.

Decontamination to background levels means that all surfaces of a cell are decontaminated to a level of 0.04 Bq/cm<sup>2</sup> for alpha emitters and of 0.4 Bq/cm<sup>2</sup> for beta-gamma emitters. The monitoring of 100% of all these surfaces is carried out twice by the Belgoprocess Health Physics Department to confirm that the decontamination is below the above mentioned levels. The operators use portable ratemeters types PCM 5/1A, Delta 3 and Electra.

Final unconditional release of the building structures will require additional random spot measurements made by an independent officially approved inspection organization. Moreover, samples will have to be taken from the remaining concrete structures, and will have to be analyzed to prove that the specific activities of these samples are well below the imposed unconditional release limits.

The results of the 100% surface measurements on those cells of the main process building that were decontaminated to background levels during the years 1995-1998 are indicated in the following table. The results for the 8 cells released in the earlier years cannot be compared as the same detail of measurement time is not available for this period.

Table 6-1 Unconditional release of concrete surfaces

Cell/ area	Concrete surface (m <sup>2</sup> )	Measurement time (hours)	Measurement rate (m <sup>2</sup> /hours)	Assistance time (hours)	Overall time (hours)	Overall rate (m <sup>2</sup> /hour)
01A	73	36.5	2.0	100	136.5	0.5
2	271	146.5	1.9	419	565.5	0.5
11	103	10	10.3	28	38.0	2.7
12	80	34	2.4	101.5	135.5	0.6
17	258	54	4.8	177.5	231.5	1.1
20	507	69	7.4	262	331.0	1.5
21A	389	107	3.6	421	528.0	0.7
22BS	25	2	12.5	2	4.0	6.3
25	66	18	3.7	40.5	58.5	1.1
26	57	14	4.1	52.5	66.5	0.9
27	184	30	6.1	96	126.0	1.5
28	507	31	16.4	104	135.0	3.8
29BI	125	52	2.4	135.5	187.5	0.7
29XS	69	14	4.9	45.5	59.5	1.2
31	288	28	10.3	96	124.0	2.3
35	257	66	3.9	201	267.0	1.0
36	158	24	6.6	71	95.0	1.7
A204	108	4	27.0	11	15.0	7.2
A401	170	36	4.7	95	131.0	1.3
B601	1,579	151	10.5	391	542.0	2.9
B602	466	83	5.6	227	310.0	1.5
Total/ Average	5,740	1,010	5.7	3,077	4,087.0	1.4

The table gives an overview of the working time in relation to the decontaminated and measured surface. One operator of the Health Physics Department is responsible for the measurement operations. He is assisted by one operator of the dismantling team to provide additional decontaminated support if required. One operator surveys the operations and provides assistance to two intervention teams working in two adjacent cells. Due to the working circumstances in the cells, in most cases, effective intervention time is limited to two hours on four. The remaining working time is spent at work preparation, accessing and leaving the work area, relaxing after working with personal protective systems, and maintenance of material and equipment. As this time period is considered to be part of the measurement activities, it is included in the overall required measurement time.

The results of the table show that, in order to obtain the required results, in the time period considered 5,740 m<sup>2</sup> of concrete surfaces had to be measured. Measurement of these concrete surfaces required:

- 1 010 man-hours from the operator of the Health Physics Department;
- 1 010 man-hours from the assisting operator of the dismantling team;
- 2 067 man-hours from the surveying and assisting operators of the dismantling team.

which brings the total amount of man-hours required to carry out the measurement activities at 4 087. The effective measurement time is 1010 man hours. About 5,7 m<sup>2</sup> of concrete surface could be measured in one effective measurement hour, requiring, however, 4 effective operator hours.

### ***6.1.2 Unconditional release measurements of decontaminated metal components from the decommissioning of the Eurochemic reprocessing plant***

In the same project, i.e. the decommissioning of the Eurochemic reprocessing plant, it was shown in a demonstration project, that it is economically interesting to decontaminate metal components to unconditional release levels using dry abrasive blasting techniques, the unit cost for decontamination being only 33% of the global cost for radioactive waste treatment, conditioning, storage and disposal. As a result, in the beginning of 1996 an industrial automatic dry abrasive blasting unit was installed in the BELGOPROCESS central decontaminated infrastructure. After 32 months of operation, at the end of 1998, 322 Mg of contaminated metal has been treated. 100 Mg of this material has been unconditionally released, having been measured twice by in-house Health Physics Department. About 217 Mg of the metal, presenting surfaces that could not be measured due to their shape, were packed in drums and were melted for unconditional release in a controlled melting facility.

The suitability of the abrasive blasting system has been verified. Impact of abrasives into the material surface, at the same time introducing contamination into the surface layer, has been checked by means of two independent control actions on samples taken from the material. Contamination levels were monitored by non-destructive gamma measurements on samples before and after decontamination. In addition, chemical control monitoring was carried out on some samples after decontamination. Surface material of the sample was removed and dissolved in a chemical solution; a radiological characterisation of this solution proved that there was no intrusion of contamination into the material surface.

The total amount of material that was unconditionally released during the years 1996 and 1997, and the related measurement hours required, are indicated in Table below. This table gives an overview of the working time in relation to the amount of material that was measured twice by the in-house Health Physics Department with a time interval of three months. One operator of the Health Physics

Department was responsible for the measurement operations. He was assisted by one operator of the decontamination team providing handling services.

Table 6.2 **Unconditional release of metal components**

Period	Amount of metal (kg)	Measurement time (hours)	Measurement rate (kg/hours)	Assistance time (hours)	Overall time (hours)	Overall rate (kg/hour)
Year 1996	18,530	380	49	413	793	23
Year 1997	71,551	1,581	45	1,717	3,298	22
<b>Total/ Average</b>	90,081	1,961	46	2,130	4,091	22

The results of the table above show that, in order to obtain the required results, in the time period considered 90,081 kg of metal components had to be monitored. Measurement of these components required:

- 1,961 man-hours from the Health Physics Department,
- 2,130 man-hours from the assisting operator of the decontamination team,

which brings the total amount of man-hours required to carry out the measurement activities at 4 091. The effective measurement time being 1,961 man-hours, about 46 kg of metal components could be measured in one effective measurement hour, requiring however, 2.1 effective operator hours.

## 6.2 Research Reactor R1, Stockholm, Sweden

### 6.2.1 Introduction

The R1 was the first Swedish nuclear reactor. It was a 1 MW reactor that operated for 16 years between 1954 and 1970. It was located in an underground cavern at the Technical University of Stockholm. The reactor was fuelled with metallic natural uranium and moderated and cooled with heavy water. There was an external reflector of graphite blocks surrounded by a biological shield of reinforced iron ore concrete.

A decommissioning plan was prepared during 1979-80. The activity content was estimated to be:

- $^{60}\text{Co}$  1 TBq
- $^{134}\text{Cs}$  0.2 GBq
- $^{152}\text{Eu}$  25 GBq
- $^{154}\text{Eu}$  5 GBq
- $^3\text{H}$  1.2 MBq

### 6.2.2 Release Measurements

A limit value for derestriction of 8 kBq/m<sup>2</sup> (0.8 Bq/cm<sup>2</sup>) was set by the authorities. All outgoing packages were checked with smear tests and survey instruments. The detection limit for the smear tests was 1.7 kBq/m<sup>2</sup>.

During the decommissioning, all salvageable material such as scrap, electric motors and construction material were surveyed carefully. All material that was below the detection limit (1.7 kBq/m<sup>2</sup>) was released for sale.

After the removal of equipment, a preliminary radiological (derestriction) survey was carried out to identify places in need for decontamination. The necessary decontamination was then performed to such a level that the removed material was below 1 kBq/kg.

The radiological surveys were conducted by means of smear testing and/or portable direct indicating instruments. The monitoring instruments were used as follows:

An FH 545 floor monitor was used for large floor areas  
sensitivity: 30 cpm per kBq·m<sup>-2</sup> (U nat)  
Typical background: 800 cpm

For smaller areas and where the floor monitor was unwieldy, a PCM5 was used:  
Sensitivity: 0.67 cps per kBq·m<sup>-2</sup> (U nat)  
Typical background: 6 cps

Equipment with a GM detector was used for normal smear tests. Sensitivity was 10 pulses per 100 s per kBq/m<sup>2</sup> (<sup>152</sup>Eu). The background was 100 pulses per 100 s.

The gamma ray spectrometer, consisting of a 17% HPGe detector and a 4 000-channel Canberra 85 MCA, was held with a remote arrangement, 5 cm from the surveyed surface. The multichannel analyzer was mounted on a wagon. The pulse rates were studied at 1.408 MeV for <sup>152</sup>Eu and 1.33 MeV for <sup>60</sup>Co. The detection limit for a 5-minute measurement was 3 kBq/m<sup>2</sup> for <sup>152</sup>Eu and 0.6 kBq/m<sup>2</sup> for <sup>60</sup>Co.

All surfaces in controlled areas were marked off in grids with one-square-metre squares in order to ensure correct surveying. The squares were given designations to permit the measurement results to be identified with the right part of the area in question.

One smear sample per square was taken on every horizontal surface in the controlled areas, as well as on walls up to a height of 2 m above the floors. On other wall surfaces and on the ceilings, one smear sample was taken in every 10th square. The smear samples were evaluated with respect to total beta count. Every 10th smear sample was also evaluated with respect to tritium. All surfaces were also surveyed with a suitable portable survey instrument.

The floors in non-controlled areas were surveyed with a portable survey instrument. At least two smear samples per area were taken for evaluation with respect to total beta count.

### 6.2.3 Costs

The reported costs for the derestriction of the R1 reactor site, i.e.

- preliminary survey;
- decontamination before final survey;
- final survey.

were 0.7 MSEK, out of a total project cost of 21.7 MSEK.

The reported figure does not include the cost of the release measurements on components, etc., removed from the site during decommissioning. The derestriction measurements and their evaluation were much more extensive and time-consuming than expected. The costs of possible delays in other segments of the projects are not either included. A rough estimate of the real total cost of release

measurements at the R1 reactor decommissioning project is 1 MSEK out of a total project cost of 21.7 MSEK (1982-83 costs).

**Reference for Chapter 6**

KÄRKER S *et al.* Decommissioning Resaerch Reactor R1 in Stockholm. Studvisk Report STUDSVIK/NW-85/1045; 1985-12-12

## 7. COSTS

This chapter gives some examples of cost calculation for projects occurring in different countries. Interpretation of those calculations and of the final cost depends on the currency fluctuation and inflation, therefore the year during which the project was carried out is mentioned and has to be taken into account.

The cost depends strongly on requirements given by the competent authorities: the number of measurements and samples to be taken and the release criteria (clearance level) to be reached. For a better understanding of the legislation of the countries, refer to chapter 5: "State of the art in different countries".

A short description of the project (quantities of material to be released, and total price of the decommissioning), measurement devices used, and radioisotopes present are given in the introduction to the cost calculation.

### 7.1 Germany – HDR

This project took place between 1994 and 1995. The HDR was mainly contaminated with  $^{137}\text{Cs}$ . The applied clearance levels were  $0.457 \text{ Bq/cm}^2$ . 100% of the surface had to be measured by the internal personnel, with hand held proportional counters. Defined samples were also taken and analysed by the internal personnel.

The German authority assigned TÜV to control the release of the site and EWE (Electro Watt Engineering) to control the release and demolishing work.

TÜV carried out a second 100% measurement of the surface (around 20 000  $\text{m}^2$ ) by High Resolution Gamma Spectrometry, and sample analyses.

The cost for the HDR control measurement performed by TÜV is:

- $\gamma$ -spectrometry equipment rental	8 months $\times$ 1 900,-	15 200,- DM
- Sample	1 000 samples $\times$ 195,-	195 000,- DM
- In-situ $\gamma$ -spectrometry	200 days $\times$ 920,-	184 000,- DM
- Expert	2 000 hours $\times$ 184,-	368 000,- DM
- Measuring personnel	2 000 hours $\times$ 138,-	276 000,- DM
- Travel expenses		44 000,- DM
- Unexpected cost due to a previous incident		564 163,- DM
	Total:	1 646 363,- DM

EWE's independent expertise cost 3.4 million DM.

- Safety reports, demolishing activity reports, recycling of material and waste management reports	Total:	3 400 000,- DM
--	--------	----------------

Internal costs (HDR costs):

- Development of a database software and documentation for the traceability of the waste flow:	1 900 000,- DM
- Decontamination and gaining access to the area inside the reactor pressure vessel:	1 200 000,- DM
- Sampling [carrot sampling and powder sample(1)] (cost = 70 DM/hour × 31 000 man hours)	2 200 000,- DM
- Personnel cost [contamination measurement (2), database, sample analyses...] (cost = 95 DM/hour × 55 000 man hours)	5 200 000,- DM
Total:	10 500 000,- DM

(1) powder samples are taken with a press to dig powder from concrete walls

(2) the contamination measurements were carried out with a Contamat, with a measuring time between 12 to 20 seconds.

The following table gives a summary of cost of the three divisions:

- TÜV control of release of the site	1.6 Million,- DM
- EWE, control of demolishing work	3.4 Million,- DM
- Internal cost	10.5 Million,- DM
Total:	15.5 Million,- DM

It must be noted that the total cost of the project reached around 100 Million DM.

## 7.2 Germany – KKN

The release measurement activities for the dismantling of the KKN took place between November '93 and August '94. The radionuclides to be measured were  $^{60}\text{Co}$ ,  $^{152}\text{Eu}$ ,  $^{154}\text{Eu}$ ,  $^{137}\text{Cs}$  and Tritium. The clearance levels applied were 0.37 Bq/cm<sup>2</sup> and 0.37 Bq/g.

The requirement for release measurements were:

For rooms inside control area:

- 26 000 m<sup>2</sup> to measure.
- 200 000 measurements with an hand held monitor (Contamat).
- 5 000 samples.

For rooms outside the control area:

- 19 500 m<sup>3</sup> to measure.
- 5 000 measurements with an hand held monitor (Contamat).
- 300 samples.

33 600 man-hours were needed for those measurements.

For rooms inside control area:

- 1 measurement per m<sup>2</sup> for the walls and ceilings.
- 100% of the floor surface had to be measured.

For rooms outside the control area:

- 1 measurement per 5-10 m<sup>2</sup> with a minimum of 1 measurement per room.



For rooms outside building (offices, machine room, entrance):

- 1 measurement per 10-50 m<sup>2</sup> with a minimum of 1 measure per local.

For the green field:

- 1 measurement per 250 m<sup>2</sup>.

For the pavement (streets):

- 1 measurement per 50 m<sup>2</sup>.
- 1 sample per 500 m<sup>2</sup>.

The total cost was 11.43 Million DM which should be compared with a total decommissioning cost of 269.0 Million DM.

### 7.3 Decommissioning of the CP-5 Research Reactor

The total project duration was 97 months. Decommissioning activities were initiated in June 1991, and the final report was issued in July 2000.

At conclusion of the Independent Verification Survey (IVS), the CP-5 facility was released as an 'Industrial Use Area', indicating that residual elevated activity remains in inaccessible areas. All accessible areas of the CP-5 facility were decontaminated to radiological background levels. The reactor vessel and internals; contaminated piping systems; and miscellaneous tanks, pumps, and associated equipment were decontaminated and/or packaged as radioactive waste. Process equipment and associated plumbing, ductwork, drain lines, etc. were dismantled; the reactor vessel internals were size-reduced in place; the reactor weight plugs and experimental equipment stored in the spent fuel pool were removed; all radioactive waste was packaged, and shipment and disposal properly documented; and a thorough survey of the facility after the removal of activated and contaminated materials was performed.

The CP-5 D&D Project was directed toward the following objectives:

- Removal of radioactive materials associated with the CP-5 facility from the ANL-E site.
- Decontamination of the CP-5 facility to unrestricted reuse levels.
- Clean-up of the CP-5 contaminated building and its formal decommissioning
- Reuse of equipment and materials in the facility, and reuse of the facility and land for other purposes.

Before initiation of the CP-5 D&D Project, the primary areas of concern associated with the D&D of the CP-5 facility included the induced radioactivity of the reactor internals and the reactor vessel itself, and the continuous release of Tritium from the biological shield. Although this Tritium release was within the allowable release limits as defined by DOE order 5 400.5, it presented a significant environmental concern. Of secondary concern were the lesser levels of radioactivity in the reactor systems, reactor components, and bioshield concrete. Based on the Auditable Safety Analysis for the D&D of the CP-5 Research Reactor, the radioactivity remaining in the activated bioshield concrete comprised <sup>60</sup>Co, <sup>152</sup>Eu, <sup>154</sup>Eu, <sup>55</sup>Fe, <sup>182</sup>Ta, <sup>110m</sup>Ag, <sup>241</sup>Am, <sup>65</sup>Zn, <sup>54</sup>Mn, <sup>14</sup>C and <sup>45</sup>Ca.

The specific objectives of the release survey included ensuring:

- Average surface contamination levels for each survey unit were within the authorised values. Small areas of residual activity (hot-spot) did not exceed three times the guideline value. The average activity within the 1 m<sup>2</sup> area containing the hot spot was within the

guideline. Reasonable efforts were made to clean up removal activity, and removable activity did not exceed the guideline value.

- Exposure rate in occupables locations were less than 5  $\mu\text{R/hr}$  above background. Exposure levels were measured at 1 m from floor/lower wall surfaces and are averaged over floor areas, not to exceed 10  $\text{m}^2$ . The maximum exposure rate at 1 m did not exceed 10  $\mu\text{R/h}$  above background.
- The average and maximum dose rates associated with surface contamination resulting from beta-gamma emitters did not exceed 0.2 mrad per hour at 1 cm.
- Reasonable efforts were made to identify and remove all activated structural material.
- Reasonable efforts were made to identify and remove contaminated paint or coatings on CP-5 Shell surfaces.
- Detailed results of the final survey are included in the DE&S Final Survey Report.

The release criteria applicable to the CP-5 shell are based on DOE Order 5400.5 and ANL-E Health Physics Procedure HPP-610. On the basis of the combination of radiological contaminants present within the CP-5 shell, the surface contamination guideline values for beta-gamma contamination were:

- 83 Bq/100  $\text{cm}^2$ , fixed and removable, average over 1  $\text{m}^2$ ;
- 250 Bq/100  $\text{cm}^2$ , maximum fixed and removable; and
- 17 Bq/100  $\text{cm}^2$ , removable contamination including Tritium.

Surface contamination guidelines for transuranic alpha contamination were:

- 1.67 Bq/100  $\text{cm}^2$ , fixed and removable, average over 1  $\text{m}^2$ ;
- 5 Bq/100  $\text{cm}^2$ , maximum fixed and removable; and
- 0.3 Bq/100  $\text{cm}^2$ , removable contamination.

Locations within the CP-5 facility were divided into affected or unaffected survey units.

The instruments used were:

- Beta gamma surface Scan: Pancake GM (HP-210/HP-260).
- Beta gamma surface Scan: 100  $\text{cm}^2$  Gas Proportional (HP-100CGS).
- Alpha Direct NaI(Tl) (SPA-3).
- Gamma Scan Compensated GM.
- Gamma Exposure Rate (HP-300).
- Beta-gamma Removable Gas Flow Proportional (Protean).
- Alpha Removable Gas Flow Prportional (Protean).

The regulator cost (DOE) which performs a 'verification survey' after each projects was \$43k (NUREG/CR-5849). As Argonne National Laboratory is the contractor to DOE to do this work, DOE pays the cost from their budget for that 'verification survey'.

Total cost for the final survey of the CP-5 Research Reactor: \$280k, compared to a total decommissioning cost of \$29.5M.

#### 7.4 Multi-Purpose research Reactor (MZFR) Karlsruhe

The Multi-Purpose Research Reactor (MZFR) was a pressurised-water reactor cooled and moderated with heavy water. The electrical output was 50 MWatt. The decommissioning concept for the complete elimination of the plant, down to green-field site, provides eight steps. A separate decommissioning licence is required for each step.

Description of the release measurements:

- Direct measurements of surface activity: one stationary measurement (radiation counter) is taken at each measuring point.
- Alpha/beta surface activity measurements by means of wipe sampling; on smooth surfaces, a wipe sample is taken over an area of 100 cm<sup>2</sup> at each measuring point. After the samples are taken, the round filters used for this purpose are each packed individually into little bags previously labeled with the measuring point numbers concerned.
- Surface activity measurement of low-energy emitters (<sup>3</sup>H); on smooth surfaces, a wipe sample is taken over an area of 100 cm<sup>2</sup> at each measuring point. The strips of foam polystyrene, sized 45×20×3 mm<sup>3</sup> used for this are inserted on location individually into the sampling vials, labeled on their lids, provided for the purpose. These wiping samples are evaluated by means of liquid scintillation counting.
- Taking and evaluating the materials samples; at each sampling location, about 100 g of substance is filled into labeled 100-ml Kautex bottles. In the release measurement laboratory, the nuclide-specific beta/gamma activities are determined, using gamma spectrometry. In addition, for some samples, the mass specific <sup>3</sup>H activities are determined by leaching or calcining.
- After decontamination measures, re-measurements must be performed to confirm the success of the decontamination (one measurement/ 1m<sup>2</sup>); depending on the kind of contamination eliminated, repeating the sampling and sample evaluation may be necessary.

For the decontamination and release measurements, the areas for which release measurements are to be performed were divided into 3 categories, with the following measurements to perform):

1. Contamination probable
  - sampling: 1 sample/10 m<sup>2</sup> or 5 samples/ wall surface for wall surfaces > 20 m<sup>2</sup> (the degree of possible surface contamination and the depth of penetration of the existing radioactivity must be determined by sample measurements and sample-taking);
  - direct measurements: 1  $\alpha, \beta$  direct measurement /m<sup>2</sup>;
  - wipe samples: 1 wipe sample/m<sup>2</sup> (The samples are preferably taken at surface cracks, holes for screw anchors, etc).
2. Contamination can not be precluded
  - sampling: 5 samples/room;
  - direct measurements: 1  $\alpha, \beta$  direct measurement /10 m<sup>2</sup>;
  - wipe samples: 1 wipe sample/10 m<sup>2</sup>.
3. Contamination improbable
  - sampling: no sample;
  - direct measurements: 1  $\alpha, \beta$  direct measurement /10 m<sup>2</sup>;
  - wipe samples: 1 wipe sample/10 m<sup>2</sup>.

The clearance levels are 0.05 Bq/cm<sup>2</sup> for alpha emitters, 0.5 Bq/cm<sup>2</sup> for  $\beta\gamma$  emitters

Building	Interior surface (m <sup>2</sup> )	Costs (DM)				Total costs
		decont.	Room category			
			Improbable	Cannot be precluded	Probable	
reactor building	15 000	1 620 000	-	880 000	560 000	ca. DM 3.0 million
Fuel pool bldg.	12 700	1 260 000	94 500	560 000	420 000	ca. DM 2.3 million
Auxiliaries complex	17 020	1 504 800	145 250	468 000	457 800	ca. DM 2.8 million
Outdoors	23 500	200 000	50 000	100 000	150 000	ca. DM 0.5 million
Total	68 220	4 584 800	289 750	1 586 800	1 587 800	ca. DM 8.6 million

### 7.5 Release measurement at Energiewerke Nord GmbH, Germany

The release measurement facility, installed in 1995 by the company NIS (and MAB), is a 16  $\gamma$ -plastic detectors. Between 1997 and 1999, the amount to be released was 9482 tons. This amount doesn't take into account the building itself and utilities (heating, electrical power, etc).

The whole cost for the operation of the release measurement facility can be divided into the following positions:

- |   |  |        |
|---|--|--------|
| - release measurement facility (hardware, software)           | ca. 600 Thousand DM                          | (1995) |
| - adaptation hardware and software (by 10 years depreciation) | ca. 120 Thousand DM<br>i.e. 72 Thousand DM/a | (1998) |
| - personal cost (10 man year)                                 | ca. 748.800 DM/a                             | (2000) |
| - logistic hardware (fork-lift trucks etc.)                   | ca. 200 Thousand DM<br>i.e. 20 Thousand DM/a | (1995) |

Thus the release of material cost:

- |   |                  |
|---|------------------|
| - release amount: 9482 tons (1997-1999) | about 0.27 DM/kg |
| - i.e. 3160.7 tons per year             |                  |

### 7.6 Japan

The site release procedure was divided into 4 steps. At the first step, contamination on concrete surfaces of the buildings was characterized by sampling and measurements. On the basis of the measurements, contamination map was created, then the contaminated concrete surfaces were removed according to the plan which was made by reflecting the contamination map. The building surface was decontaminated in each area, then the final radiological was conducted to confirm that there is no radioactivity. The final radiological survey was conducted by two steps: first, handy type detector, second, measurement of gamma-ray spectra. Figure 1 shows follow of site release on the JPDR decommissioning activities.

## Survey Meters

The final radiological survey was conducted at each room in the JPDR facilities using gas flow counter type and scintillation counter type survey meters, which has 160 cm<sup>2</sup> or 1 800 cm<sup>2</sup> and 900 cm<sup>2</sup> of the sensitive window area, respectively. These survey meters are capable of 0.4 Bq/cm<sup>2</sup> for beta-emitters under normal background conditions. The specification of these meters is given in Table 7.1.

Table 7.1 **Specification of Survey Meters**

Type of Survey Meter	Sensitive Window Area (m <sup>2</sup> )	Efficiency of Contamination Source	Instrument Efficiency (4π)
Gas Flow Counter	160	0.25	0.23, 0.27
Gas Flow Counter	1 800	0.25	0.22
Scintillation Counter	900	0.25	0.20

The radioactivity of surfaces contamination was evaluated in compliance with the Japanese Industrial Standard. The surface concentration of radioactivity (A) is given by the following equation:

$$A = N / (e_i \cdot x \cdot W \cdot x \cdot e_s) \quad (1)$$

where,

- N: the net count rate in reciprocal seconds;
- e<sub>i</sub>: the instrument efficiency for beta radiation;
- W: the area of the sensitive window of the measuring instrument;
- e<sub>s</sub>: the efficiency of the contamination source.

As a result of plausible and conservation assumptions, e<sub>s</sub>=0.25 [beta-emitters (0.15 MeV < E<sub>b</sub> < 0.4 MeV)] is used in the absence of more precisely known values: Since maximum beta energy (E<sub>b</sub>) of <sup>60</sup>Co is 0.31788 MeV, e<sub>s</sub> = 0.25 was used in the final survey activity.

The instrument efficiency, e<sub>i</sub> for beta radiation is given by the following equation.

$$e_i = N / (p \times W) \quad (2)$$

where, p is surface emission rate per unit area of the reference source.

The instrumental efficiencies of these meters are given in Table 7.1 for those calculations.

## Radiological Survey

The final radiological survey was conducted after decontamination of the building inner surface. First, radioactivity was surveyed to each area by the survey meters. In practice, final survey of radioactivity was performed on every 0.8 m by 0.8 m square blocks moving the survey meters, and the highest counting rate in each block was recorded. Samples were then taken from each area for confirmation of that the radioactivity of <sup>60</sup>Co is low (3 Bq/kg) enough compared with the natural background. The final confirmation of radioactivity was conducted in such a way that one sample per each 10 m<sup>2</sup> area at penetrated contamination areas or one sample per each room at surface contamination areas are taken and the radioactivity of the sample was measured by the Ge-detector with a multi-channel pulse height analyzer to confirm that there is no contamination in the sample.

### Inspection by Authority

On the basis of site release procedures, which was submitted to the Science and Technology Agency(STA), confirmatory inspection was conducted by STA staffs. The confirmatory inspection was based on the review of measurement records. Some areas were then selected to measure the radioactivity again. The measured radioactivity was compared with the records which obtained in the final radiological surveys. After conforming that the measurement records were reasonable and the comparison between previous and newly measured radioactivity was in same level, the controlled areas were cancelled.

### Manpower Expenditure

The Manpower expenditure for the final radiological survey was measured as shown in Table 7.2. The total manpower expenditure in the final radiological survey was counted to be 4 400 man-days. Within the value, the manpower expenditure of 8,361 m<sup>2</sup> areas survey resulting in 2 760 man-days in reactor, turbine and rad-waste buildings.

### Unit cost factors

The area size in final radiological survey is only clear in reactor, turbine and rad-waste buildings as shown in Table III. On the basis of the data in final radiological survey in the three buildings, the unit cost for radiological survey was estimated as follows.

Manpower in three blds: 2 759 man-days  
 Area in three blds: 8 361 m<sup>2</sup>  
 Unit Cost factor: 22 000 yen/m<sup>2</sup>

Table 7.2 **Breakdown of Manpower Expenditure**

Reactor internals	:	9 900
Piping to RPV	:	2 700
RPV	:	10 200
Bioshield	:	18 500
Components	:	39 800
Decontamination building	:	15 300
Final survey of radioactivity	:	4 400
Building demolition	:	14 200
Administrative work	:	29 600

Unit: man-days

Table 7.3 **Manpower Expenditure in Final Radiological Survey**

Data on major three buildings

Work Items		Reactor Bld.	Turbine Bld.	Rad-waste Bld
		man.days	man.days	man.days
A	Covering of floor by vinyl mats		13.5	
	Installation of contamination control tent			0.9
	Identification of measurement area	162.2	159.21	178.5
	Installation of scaffoldings	164.4	112.1	38.0
	Preparation of materials and tools	72.0	34.1	20.3
	Transportation of containers		0.9	0.7
	Setting of measurement machines		1.2	39.0
	Survey of radiation measurement area	2.5	16.7	32.8
	Sub-total	401.1	337.7	310.2
B	Final survey of radioactivity	173.7	283.5	570.6
	Others		1.4	
	Sub-total	173.7	284.9	570.6
C	Removal of contamination control tent		3.2	
	Removal of scaffoldings	59.7	40.1	19.2
	Transportation of materials and tools	30.4	41.8	23.0
	Transportation of waste	4.9	12.4	11.2
	Cleanup	76.6	249.0	110.2
	Sub-total	171.6	346.5	163.6
Total		746.4	969.1	1,044.4

A: Preparation, B : Measurement, C : Cleanup

area (m <sup>2</sup> )	2,114	4,380	1,867
------------------------	-------	-------	-------





## 8. PROBLEMS ENCOUNTERED OUTSIDE THE NUCLEAR FIELD

Radiation protection and the management of radioactive material have hitherto been concerned mainly with artificial nuclides arising within the nuclear fuel cycle. In the last few years, there has been an increasing awareness of naturally occurring radioactive material (NORM) and the enhancement of its concentration in various non-nuclear industrial processes. A common feature of these processes is that they use raw materials or feed stocks that originated from the earth. Although the industries are sophisticated regarding their own respective processes, they have little or no knowledge regarding radioactivity. The first problem with radioactive material outside the nuclear field is one of recognition. Even when recognized, most plants handling such material are not aware that radioactivity is being concentrated in the various technological processes. Very often, the first indication is when waste is taken to a melting plant or a landfill with portal monitors for radioactivity, which are usually set to alarm at a level only slightly above background.

This technologically enhanced NORM is of the same activity levels as very low level waste and is very similar to the candidate material for exemption and clearance in the nuclear industry, but occurs in quantities that are huge in comparison, as is illustrated in Table 8.1, which shows the volumes and the radioactivity in some of the technologically enhanced NORM arising annually in the United States. More or less comparable quantities of NORM arise in Europe, with similar concentrations of radioactivity, as shown in Table 8.2.

Steel melters recycling scrap have become increasingly aware of the risks of radioactivity contaminating their products. Even though the most serious incidents have involved  $^{60}\text{Co}$  and  $^{137}\text{Cs}$  sources, the largest single contribution to radioactivity in scrap in the United States has been NORM [8.1]. In any event, monitoring devices at melting plants, just like human beings, cannot discriminate between natural and artificial radionuclides.

### 8.1 Form of the material

Due to the evolution of the nuclear field, procedures and practices have developed to control contaminated equipment and waste. Thus, to a large degree, persons working in the nuclear field have a good idea of where to look and what to look for. Outside the nuclear field, little or no control has existed, which has resulted in plant yards containing large quantities of scrap metal which may contain radioactive material. Additionally, there are landfills, settling ponds, and waste pits which may also contain radioactive material.

### 8.2 Measurement Problem

Measurement problems can be divided into three classes:

- sampling;
- detection;
- measurement.

- Sampling

At plant sites, tons of scrap may be stored. If the potential exists for the presence of alpha emitters with little or no gamma (such as  $^{230}\text{Th}$ ), it is difficult to economically collect enough samples to adequately define the extent of the radioactive contamination. Land fills and ponds may cover tens of hectares to depths of several metres. Raw material and feed stocks may come from many

sources which can vary in their radioactive material content (examples: titanium ores from Australia may contain up to 10 times more radioactive material than ore from South Africa and the radioactive material in Bauxite may vary by over a factor of 3). Unless one knows that all original raw or feed material came from a common source (highly unlikely), then to adequately define the extent of the radioactive contamination requires a rigorous sampling plan.

- Detection

If one can assume that the radioactive material is one of the long lived natural decay series with all of the elements of the series in secular equilibrium, then the detection is relatively simple using standard gamma detection techniques. However, if the processing of the raw or feed material results in an upset of the secular equilibrium, detection may be difficult (for examples the separation of natural gas from crude will carry  $^{222}\text{Rn}$  with it, and the  $^{222}\text{Rn}$  will decay to  $^{210}\text{Pb}$ , and its daughter  $^{210}\text{Po}$ , which are essentially pure beta and alpha emitters respectively). In the selection and evaluation of detection methods, one must know or determine the physical and chemical processes involved.

- Measurement conditions

Measurement of alpha in the field is usually difficult for at least two reasons:

- alpha measurement instruments are not rugged and are easily damaged in the field,
- there is usually a layer of dust, oil, oxidation etc., making alpha measurement difficult or impossible.

If measurements are to be made in the field, such as contamination levels on equipment or scrap metal, such measurements will most likely be limited to beta-gamma measurements.

### 8.3 Regulation of NORM

The EC came out with a new Directive in May 1996, with revised basic safety standards (BSS) for the radiation protection of both workers and the general public [8.2]. The Directive covers radioactivity in both nuclear and non-nuclear industries and had to be ratified by member states within 4 years, i.e. by May 2000. In the BSS, industries are divided into “practices” (where radionuclides are, or have been processed in view of their fissile or fertile properties) and “work activities” (where the presence of radioactivity is incidental). Broadly speaking, “practices” refer to the nuclear industries, while “work activities” to the non-nuclear ones, i.e. industries like coal, oil and gas or phosphate industries. The table of exemption values in the new EC-BSS covers only practices. The exemption values for work activities are not explicitly given. It is not clear in the BSS what is proposed for the TENORM industries. Both in Germany [8.7] and in Holland [8.8], however, the level of 1 mSv/year individual dose is being used.

The EC-BSS gives a nuclide specific table of exemption levels for practices. A typical value for nuclides of interest ( $^{60}\text{Co}$ ,  $^{137}\text{Cs}$  and  $^{226}\text{Ra}$ ) is 10 Bq/g. The BSS does not give a corresponding table for work activities. However, it was noted at the NORM II meeting in Krefeld, Germany [8.9], that much higher levels were being used in certain European countries:

- Germany: 500 Bq/g for NORM total activity;  
65 Bq/g for  $^{226}\text{Ra}$ .
- Holland: 100 Bq/g for NORM.
- Norway uses the “nuclear” level of 10 Bq/g also for the exemption of  $^{226}\text{Ra}$ , and  $^{228}\text{Ra}$  and  $^{210}\text{Pb}$  from the oil and gas industry.

The IAEA, in a draft document issued in connection with the revision of Safety Series 89, propose a 1 mSv/year individual dose criterion for the exclusion of TENORM from regulatory control.

In the United States TENORM is only regulated by the states. A draft set of regulations for technologically enhanced NORM (TENORM) was given out in February 1997 by the Conference of Radiation Control Programme Directors (CRCPD). The CRCPD is an organisation primarily consisting of directors and technical staff from state and local radiation control programmes and functions as the common forum for state, local and federal regulatory agencies to address NORM-related health and safety issues. Several states have already regulations in place to meet their specific individual needs. There is, however, no uniformity in these regulations. One of the main aims of CRCPD is working towards uniformity in regulations governing radiation [8.3].

The American National Standards Institute (ANSI) has published a draft guide (N13.53) for the control and release of TENORM [8.10]. This suggests administrative release levels based on a maximum of 100  $\mu\text{Sv}/\text{year}$  (“less than 10 mrem in practice”).

**Table 8.1 Sources, volumes and concentrations of naturally occurring radioactive materials [8.4]**

Waste Stream	Production Rate per Yr.	Total U Bq/kg	Total Th Bq/kg	Total Ra Bq/kg
Phosphate	$5.0 \times 10^{10}$ kg	bkgd - 3 000	bkgd - 1 800	400 - 3 700 000
Phosphogypsum	$4.8 \times 10^{10}$ kg	bkgd - 500	bkgd - 500	900 - 1 700
Slag	$1.5 \times 10^9$ kg	800 - 3 000	700 - 1 800	400 - 2 100
Scale	$4.5 \times 10^6$ kg	**	**	1 100 - 3 700 000
Coal Ash	$6.1 \times 10^{10}$ kg	100 - 600	30 - 300	100 - 1 200
Fly Ash	$4.4 \times 10^{10}$ kg	**	**	**
Bottom Ash	$1.7 \times 10^{10}$ kg	**	**	**
Petroleum Production	$2.6 \times 10^8$ kg	**	**	bkgd - 3 700 000
Scale	$2.5 \times 10^7$ kg	**	**	bkgd - 3 700 000
Sludge	$2.3 \times 10^8$ kg	**	**	bkgd - 3 700
Petroleum Processing	**	**	**	***
Refineries	**	**	**	> 4 000
Petrochem Plants	**	**	**	> 4 000
Gas Plants	**	**	**	***
Water Treatment	$3.0 \times 10^8$ kg	**	**	100 - 1 500 000
Sludges	$2.6 \times 10^8$ kg	**	**	100 - 1 200
Resins	$4.0 \times 10^7$ kg	**	**	300 - 1 500 000
Mineral Processing	$1.0 \times 10^{12}$ kg	6 - 129 000	8 - 900 000	< 200 - 129 000
Rare Earths	$2.1 \times 10^7$ kg	26 000 - 129 000	9 000 - 900 000	13 000 - 129 000
Zr, Hf, Ti, Sn	$4.7 \times 10^8$ kg	6 - 3 200	8 - 660 000	300 - 18 000
Alumina	$2.8 \times 10^9$ kg	400 - 600	500 - 1200	300 - 500
Cu and Fe	$1.0 \times 10^{12}$ kg	< 400	< 400	< 200
Geothermal Waste	$5.4 \times 10^7$ kg	**	**	400 - 16 000
Paper Mills	**	**	**	> 3700

\* Derived partially from US EPA, 1993 [8.5]

\*\* Data not available

\*\*\*  $^{210}\text{Pb}$  and  $^{210}\text{Po}$

Table 8.2:1 Summary [8.6]

PROCESS	SCALE OF OPERATION	PROMINENT RADIONUCLIDES	TYPICAL ACTIVITY CONCENTRATION (Bq/kg) AND ENHANCEMENT	RADIOLOGICAL IMPACT (Occupational) (Public)
i) Feed materials ii) Product iii) By-product/Waste  Power production from coal: i) Coal. ii) Energy production. iii) Coal ash (bulk and aerosol), sludges	Worldwide usage. ii) 30 Mt/a coal ash in the EU.	i) $^{238}\text{U}$ and $^{232}\text{Th}$ + d's. iii) As feed material but more volatile components ( $^{210}\text{Po}$ and $^{210}\text{Pb}$ ) follow airborne pathways.	i) 20 Bq/kg for each of $^{238}\text{U}$ and $^{232}\text{Th}$ , both with d's in equilibrium. iii) Factor 10 enhancement for $^{238}\text{U}$ and $^{232}\text{Th}$ , perhaps a factor 100 for volatiles: $^{210}\text{Pb}$ , $^{210}\text{Po}$ .	(O) Active dust exposure: $^{210}\text{Pb}$ and $^{210}\text{Po}$ , ~ $\mu\text{Sv/a}$ . (P) Negligible dose from power plant, but poorly disposed ash can contaminate food chain $10^5$ $\mu\text{Sv/a}$ .
Phosphate ore processing and use: i) Phosphate rock. ii) Phosphoric acid/fertiliser iii) Slag, slurry, offgas.	i) 126 Mt/a (world). ii) 4 Mt/a phosphate fertiliser in EU.	i) $^{238}\text{U}$ and $^{232}\text{Th}$ + d's. ii) Up to 50 % enhancement, especially $^{226}\text{Ra}$ in fertilisers iii) $^{226}\text{Ra}$ , $^{210}\text{Pb}$ , $^{210}\text{Po}$ .	i) 100s – 1 000s Bq/kg in ore. ii) 100s – 1 000s Bq/kg in fertiliser iii) 5 000 Bq/kg $\text{Ra}^{226}$ in phosphogypsum	(O) 5 $\mu\text{Sv/a}$ for plant workers and 100s $\mu\text{Sv/a}$ for transport and storage workers. (P) 2 $\mu\text{Sv/a}$ from fertilisers up to several mSv/a doses from certain marine pathways otherwise only $\mu\text{Sv/a}$ doses from alternate pathways.
Recycling waste in building materials: i) By-products/wastes. ii) Bricks, concrete, cement... iii) Slag, scales, gases, used products.	i) Process wastes recycled whenever possible: coal ash, phosphogypsum, slag... ii) Only lower activity materials used in inhabited structures. iii) Further recycling possible.	$^{238}\text{U}$ and $^{232}\text{Th}$ + d's as from process wastes. ii) $^{222}\text{Rn}$ + d's accumulation in buildings, otherwise external exposures from gamma emitting nuclides.	ii) 50 - 100 Bq/kg $^{238}\text{U}$ / $^{232}\text{Th}$ / $^{226}\text{Ra}$ .	(O) 100s $\mu\text{Sv/a}$ from dusty operations. (P) Up to 500 mSv/a from close association with active buildings and roads/Rn + d's build-up in unventilated buildings
Rare earths and zirconium: i) Rare earth and zirconium ores. ii) Refined ores, glazes, polish, refractories iii) Solid waste, aerosols, used products.	i) 0.7 Mt/a of zirconium ore (world), 30kt/a rare earths in EU. ii) Milling and processing operations on 1 y in EU.	$^{238}\text{U}$ and $^{232}\text{Th}$ + d's.	100s – 1 000s Bq/kg for both ores, products and wastes.	(O) Minimal $\mu\text{Sv/a}$ doses due to protective measures. (P) Little impact noted.

Table 8.2:2 Summary [8.6]

PROCESS	SCALE OF OPERATION	PROMINENT RADIONUCLIDES	TYPICAL ACTIVITY CONCENTRATIONS (Bq/kg) AND ENHANCEMENT	RADIOLOGICAL IMPACT (Occupational) (Public)
i) Feed materials ii) Product iii) By-product/Waste  Metal smelting: i) Metal ores (Sn, Nb, Pb, Bi, Fe...) ii) Metals / alloys (steels). iii) Slags scales, aerosols and gases.	130 Mt/a crude steel in EU. Niobium steel production much smaller.	ii) $^{210}\text{Pb}$ and $^{210}\text{Po}$ in tin smelting. iii) $^{238}\text{U}$ and $^{232}\text{Th}$ in slag, $^{210}\text{Pb}$ and $^{210}\text{Po}$ in dusts.	i) 500- 100 Bq/kg in ores. iii) Various waste products 102 105 Bq/kg. 10 000s Bq/kg $^{238}\text{U}$ and $^{232}\text{Th}$ in niobium steel ore, product and waste.	(O) Fractions of mSv/a from tin smelting and low doses from steel production. Niobium steel production: 4 mSv/a with protective measures. (P) 10s $\mu\text{Sv/a}$ from various exposure pathways.
Storage and use of copper mining tailings: i) Copper ore. ii) Copper. iii) Rock, slags sludge, roast product.	Exploitation of high activity tailings previously occurred in Eastern Germany.	i) $^{238}\text{U}$ and $^{232}\text{Th}$ + d's in ores. ii) $^{226}\text{Ra}$ , $^{210}\text{Pb}$ and $^{210}\text{Po}$ progeny in solid and sludge wastes. iii) $^{210}\text{Pb}$ and $^{210}\text{Po}$ in airborne waste streams	Slags: 1000 Bq/kg $^{226}\text{Ra}$ . some sludges and furnace wastes have up to 200 Bq/kg $^{210}\text{Pb}$ and $^{210}\text{Po}$ .	(O) Nil- industry closed. (P) Local waste piles: dose rates 100s – 1 000s $\mu\text{Sv/h}$
Oil and gas production: i) Natural oil and gas reservoirs. ii) Purified oil and gas. iii) Sludge, scale.	i) Largely North Sea regions. ii) 140 Mt/a oil in EU, 2 x 10 <sup>11</sup> m <sup>3</sup> /a gas in EU. iii) 10 000/m <sup>3</sup> of active waste before treatment from EU oil and gas industries.	i) $^{238}\text{U}$ and $^{232}\text{Th}$ 0d's. ii) Natural gas has radon content. iii) $^{226}\text{Ra}$ , $^{210}\text{Pb}$ and $^{210}\text{Po}$ in scales and sludges	ii) 300 Bq/m <sup>3</sup> $^{222}\text{Rn}$ on average in natural gas. iii) 105 Bq/kg each in sludges and up to several times this in scales.	(O) 1-2 mSv/a from working with oil in the vicinity of scales and sludges (P) Little contact between the public and the industries.
Other minor processes: i) Various. ii) Chemicals, water usages, glass... iii) Various.	Generally small scale operations with limited public contact. Water use in treatment plants and spas. Chemical industry scale in not recorded.	Various: $^{238}\text{U}$ and $^{232}\text{Th}$ + progeny. Water: radon plus progeny can be significant.	Little known about the radionuclide involvement in the chemical industry. Perhaps as much as 1 Bq/kg $^{226}\text{Ra}$ in mineral waters.	(O) Tend to be localised to parts of the body. Perhaps several mSv/a from radon d's to those workers in spas. (P) 10s $\mu\text{Sv/a}$ from radon in water supplies.

**References for Chapter 8**

- 8.1. VAN WEERS A.W. et al  
Current practices of dealing with natural radioactivity from oil and gas production in EU member states.  
Nuclear Science and Technology,  
European Commission EUR 17621 EN, 1997
- 8.2. EUROPEAN COMMISSION  
Council Directive 96/29/Euratom of 13 May 1996 laying down basic safety standards for the protection of workers and the general public against the dangers arising from ionising radiation.
- 8.3. CRCPD  
Part N: Regulation and Licensing of Technologically Enhanced Naturally Occurring Radioactive Materials (TENORM). Draft,  
Frankfort, Kentucky, February 1997
- 8.4. SCOTT L.M.  
Regulation of Naturally Occurring Radioactive Materials in Non-nuclear Industries.  
IAEA Specialists' Meeting on Exclusion, Exemption and Clearance, Vienna, May 1997.
- 8.5. US ENVIRONMENT PROTECTION AGENCY  
Diffused NORM Waste - Waste Characterisation and Preliminary Risk Assessment,  
April 1993, Draft RAE - 9232/1, 1993.
- 8.6. MARTIN A. *et al.*  
Materials containing natural radionuclides in enhanced concentrations.  
Nuclear Science and Technology,  
European Commission EUR 17625 EN 1997
- 8.7. SAPPOCK M., QUADE U., WIENERT R.,  
Experiences with the Release of Radioactive Waste and Problems related to their Storage in Final Depository. Waste Management '99, Tucson, Arizona, 1999.
- 8.8. SHELL SAFETY AND HEALTH COMMITTEE,  
Ionisation Radiation Safety Guide. Shell Internationale Petroleum Maatchappij BV, The Hague, The Netherlands, 1993.
- 8.9. EUROPEAN COMMISSION/KEMA/SIEMPELKAMP,  
Proceedings of the NORM II Second International Symposium.
- 8.10. AMERICAN NATIONAL STANDARDS INSTITUTE,  
Guide for Control and Release of Technologically Enhanced Naturally Occurring Radioactive Material, ANSI Draft (Ver. 2), March 1999 update.





## CONCLUSIONS

As can be seen in chapter 5, there is no international clearance levels, in spite of efforts conducted by the European Commission, the IAEA and the OECD/NEA. On the other hand, the large amounts of waste due to increasing dismantling projects show that there is a need to find internationally accepted release levels.

Recycling of material is in most cases a more “environmental friendly” option than producing new material e.g. from ore. Reuse of facilities is also advisable in most situations. This calls for setting regulatory limits for recycling and reuse at levels that balance the advantage of recycling and the risk (including the radiation risk) of using the recycled material.

This report shows that the technical ability is there: large amounts of low level waste have already been monitored with detection limits below  $1 \text{ Bq}\cdot\text{g}^{-1}$  or  $1 \text{ Bq}\cdot\text{cm}^{-2}$ . The more the detection limit is low, the more the resulting cost will be higher. Experience has already shown that the cost of waste measurement amounts between a few % to 20% of the total project cost.

Measurements of contamination at the lowest release levels, as regulated or proposed to be regulated e.g.  $0.4 \text{ Bq}\cdot\text{cm}^{-2}$ , is time consuming, costly, and need extreme quality assurance.

The necessary time, cost, and quality assurance can be reduced

- if averaging methods are accepted, such as averaging over large areas or volumes,
- if information concerning previous use of different parts of a facility can be used, such that alpha measurements only need to be performed in those areas where there is a great probability to find alpha contamination above the release level,
- if the release levels are set higher (e.g. up to 10 times higher) than  $0.4 \text{ Bq}/\text{cm}^2$ .

It must be noted that neither of these “less restrictive” release measurement options leads to release a large amounts of materials or areas from regulatory control with contamination levels above  $0.4 \text{ Bq}/\text{cm}^2$ , as most of the material and areas released will be far below the limits.

In general, systems that are able to integrate measurements over large areas ( $\gamma$  spectrometry) are generally to be preferred. As a matter of fact, experience has shown that it is 2 or 3 times cheaper than hand-held monitoring. This kind of devices are increasingly being used.

As radiation poses the same danger per unit of effective dose, nuclear practices and NORM-practises should be judged according to the same radiation protection standards taking due consideration to the justification of each respective practice. As can be seen from this report, this is not the case.